



OM-225 389G

2006-12

Processes



TIG (GTAW) Welding



Stick (SMAW) Welding

Description



Arc Welding Power Source

ENGLISH

FRANÇAIS

ESPAÑOL

Syncrowave[®] 200

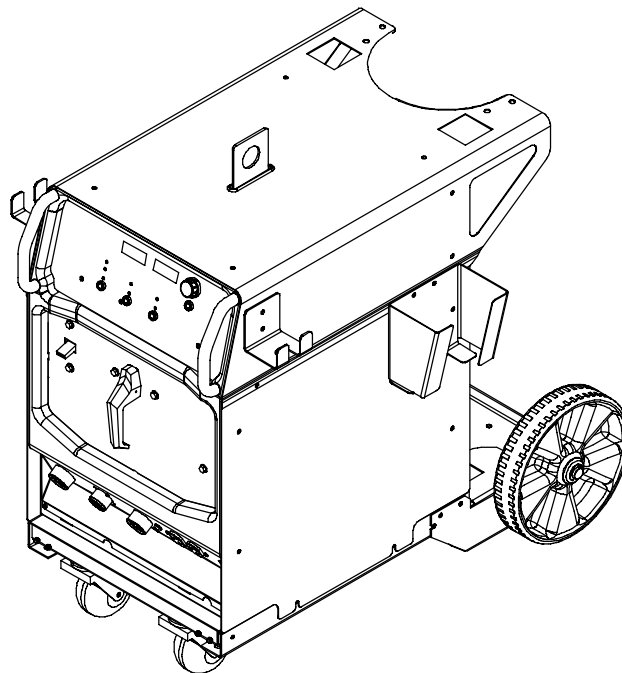

Visit our website at
www.MillerWelds.com

OWNER'S MANUAL

File: TIG (GTAW)



From Miller to You

Thank you and congratulations on choosing Miller. Now you can get the job done and get it done right. We know you don't have time to do it any other way.

That's why when Niels Miller first started building arc welders in 1929, he made sure his products offered long-lasting value and superior quality. Like you, his customers couldn't afford anything less. Miller products had to be more than the best they could be. They had to be the best you could buy.

Today, the people that build and sell Miller products continue the tradition. They're just as committed to providing equipment and service that meets the high standards of quality and value established in 1929.

This Owner's Manual is designed to help you get the most out of your Miller products. Please take time to read the Safety precautions. They will help you protect yourself against potential hazards on the worksite.

We've made installation and operation quick and easy. With Miller you can count on years of reliable service with proper maintenance. And if for some reason the unit needs repair, there's a Troubleshooting section that will help you figure out what the problem is. The parts list will then help you to decide the exact part you may need to fix the problem. Warranty and service information for your particular model are also provided.



Miller is the first welding equipment manufacturer in the U.S.A. to be registered to the ISO 9001:2000 Quality System Standard.

Miller Electric manufactures a full line of welders and welding related equipment. For information on other quality Miller products, contact your local Miller distributor to receive the latest full line catalog or individual specification sheets. **To locate your nearest distributor or service agency call 1-800-4-A-Miller, or visit us at www.MillerWelds.com on the web.**



Working as hard as you do – every power source from Miller is backed by the most hassle-free warranty in the business.



TABLE OF CONTENTS

SECTION 1 – SAFETY PRECAUTIONS - READ BEFORE USING	1
1-1. Symbol Usage	1
1-2. Arc Welding Hazards	1
1-3. Additional Symbols For Installation, Operation, And Maintenance	3
1-4. California Proposition 65 Warnings	3
1-5. Principal Safety Standards	4
1-6. EMF Information	4
SECTION 2 – INSTALLATION	5
2-1. Included with Your Unit	5
2-2. Selecting A Location	5
2-3. Dimensions And Weights	6
2-4. Specifications	6
2-5. Rating Labels	7
2-6. Duty Cycle Chart	7
2-7. DC Volt-Ampere Curves	8
2-8. AC Volt-Ampere Curves	8
2-9. Weld Output Terminals And Selecting Cable Sizes	8
2-10. Remote 14 Receptacle	9
2-11. 115 Volts AC Duplex Receptacle And Supplementary Protector CB1	10
2-12. Shielding Gas Connections	10
2-13. Typical TIG Connections	11
2-14. Typical Stick Connections	12
2-15. Electrical Service Guide	12
2-16. Connecting Input Power In 208–230 Volt Models	13
2-17. Connecting Input Power In 460/575 Volt Models	13
SECTION 3 – OPERATION	15
3-1. Controls	15
3-2. Ammeter, Voltmeter And Parameter Display	16
3-3. Amperage Control	16
3-4. Process Control	16
3-5. Pulse Control	17
3-6. Balance/DIG Control	18
3-7. Factory Parameter Defaults And Range And Resolution	19
3-8. Postflow Control	20
3-9. Selecting Syncro Start Characteristics	21
3-10. Pulser Peak And Background	22
3-11. Timer/Cycle Counter	23
3-12. Software Number/Revision	24
SECTION 4 – MAINTENANCE AND TROUBLESHOOTING	25
4-1. Routine Maintenance	25
4-2. Adjusting Spark Gaps	25
4-3. Voltmeter/Ammeter Help Displays	26
4-4. Troubleshooting	27
SECTION 5 – ELECTRICAL DIAGRAM	28
SECTION 6 – HIGH FREQUENCY	30
6-1. Welding Processes Requiring High Frequency	30
6-2. Incorrect Installation	30
6-3. Correct Installation	31
SECTION 7 – SELECTING AND PREPARING TUNGSTEN ELECTRODE FOR DC OR AC WELDING	32
7-1. Selecting Tungsten Electrode (Wear Clean gloves To Prevent Contamination Of Tungsten)	32
7-2. Preparing Tungsten Electrode For Welding	33

TABLE OF CONTENTS

SECTION 8 – GUIDELINES FOR TIG WELDING (GTAW)	34
8-1. Positioning The Torch	34
8-2. Torch Movement During Welding	35
8-3. Positioning Torch Tungsten For Various Weld Joints	36
SECTION 9 – STICK WELDING (SMAW) GUIDELINES	37
SECTION 10 – PARTS LIST	46
10-1. Recommended Spare Parts	46
WARRANTY	

SECTION 1 – SAFETY PRECAUTIONS - READ BEFORE USING

som _3/05

▲ **Warning: Protect yourself and others from injury — read and follow these precautions.**

1-1. Symbol Usage



Means Warning! Watch Out! There are possible hazards with this procedure! The possible hazards are shown in the adjoining symbols.

▲ **Marks a special safety message.**

☞ Means "Note"; not safety related.



This group of symbols means Warning! Watch Out! possible ELECTRIC SHOCK, MOVING PARTS, and HOT PARTS hazards. Consult symbols and related instructions below for necessary actions to avoid the hazards.

1-2. Arc Welding Hazards

▲ **The symbols shown below are used throughout this manual to call attention to and identify possible hazards. When you see the symbol, watch out, and follow the related instructions to avoid the hazard. The safety information given below is only a summary of the more complete safety information found in the Safety Standards listed in Section 1-5. Read and follow all Safety Standards.**

▲ **Only qualified persons should install, operate, maintain, and repair this unit.**

▲ **During operation, keep everybody, especially children, away.**



ELECTRIC SHOCK can kill.

Touching live electrical parts can cause fatal shocks or severe burns. The electrode and work circuit is electrically live whenever the output is on. The input power circuit and machine internal circuits are also

live when power is on. In semiautomatic or automatic wire welding, the wire, wire reel, drive roll housing, and all metal parts touching the welding wire are electrically live. Incorrectly installed or improperly grounded equipment is a hazard.

- Do not touch live electrical parts.
- Wear dry, hole-free insulating gloves and body protection.
- Insulate yourself from work and ground using dry insulating mats or covers big enough to prevent any physical contact with the work or ground.
- Do not use AC output in damp areas, if movement is confined, or if there is a danger of falling.
- Use AC output ONLY if required for the welding process.
- If AC output is required, use remote output control if present on unit.
- Additional safety precautions are required when any of the following electrically hazardous conditions are present: in damp locations or while wearing wet clothing; on metal structures such as floors, gratings, or scaffolds; when in cramped positions such as sitting, kneeling, or lying; or when there is a high risk of unavoidable or accidental contact with the workpiece or ground. For these conditions, use the following equipment in order presented: 1) a semiautomatic DC constant voltage (wire) welder, 2) a DC manual (stick) welder, or 3) an AC welder with reduced open-circuit voltage. In most situations, use of a DC, constant voltage wire welder is recommended. And, do not work alone!
- Disconnect input power or stop engine before installing or servicing this equipment. Lockout/tagout input power according to OSHA 29 CFR 1910.147 (see Safety Standards).
- Properly install and ground this equipment according to its Owner's Manual and national, state, and local codes.
- Always verify the supply ground – check and be sure that input power cord ground wire is properly connected to ground terminal in disconnect box or that cord plug is connected to a properly grounded receptacle outlet.
- When making input connections, attach proper grounding conductor first – double-check connections.
- Frequently inspect input power cord for damage or bare wiring – replace cord immediately if damaged – bare wiring can kill.

- Turn off all equipment when not in use.
- Do not use worn, damaged, undersized, or poorly spliced cables.
- Do not drape cables over your body.
- If earth grounding of the workpiece is required, ground it directly with a separate cable.
- Do not touch electrode if you are in contact with the work, ground, or another electrode from a different machine.
- Do not touch electrode holders connected to two welding machines at the same time since double open-circuit voltage will be present.
- Use only well-maintained equipment. Repair or replace damaged parts at once. Maintain unit according to manual.
- Wear a safety harness if working above floor level.
- Keep all panels and covers securely in place.
- Clamp work cable with good metal-to-metal contact to workpiece or worktable as near the weld as practical.
- Insulate work clamp when not connected to workpiece to prevent contact with any metal object.
- Do not connect more than one electrode or work cable to any single weld output terminal.

SIGNIFICANT DC VOLTAGE exists in inverter-type welding power sources after removal of input power.

- Turn Off inverter, disconnect input power, and discharge input capacitors according to instructions in Maintenance Section before touching any parts.

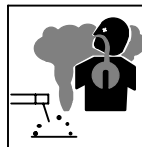

FUMES AND GASES can be hazardous.

Welding produces fumes and gases. Breathing these fumes and gases can be hazardous to your health.

- Keep your head out of the fumes. Do not breathe the fumes.
- If inside, ventilate the area and/or use local forced ventilation at the arc to remove welding fumes and gases.
- If ventilation is poor, wear an approved air-supplied respirator.
- Read and understand the Material Safety Data Sheets (MSDSs) and the manufacturer's instructions for metals, consumables, coatings, cleaners, and degreasers.
- Work in a confined space only if it is well ventilated, or while wearing an air-supplied respirator. Always have a trained watch-person nearby. Welding fumes and gases can displace air and lower the oxygen level causing injury or death. Be sure the breathing air is safe.
- Do not weld in locations near degreasing, cleaning, or spraying operations. The heat and rays of the arc can react with vapors to form highly toxic and irritating gases.
- Do not weld on coated metals, such as galvanized, lead, or cadmium plated steel, unless the coating is removed from the weld area, the area is well ventilated, and while wearing an air-supplied respirator. The coatings and any metals containing these elements can give off toxic fumes if welded.



ARC RAYS can burn eyes and skin.

Arc rays from the welding process produce intense visible and invisible (ultraviolet and infrared) rays that can burn eyes and skin. Sparks fly off from the weld.

- Wear an approved welding helmet fitted with a proper shade of filter lenses to protect your face and eyes when welding or watching (see ANSI Z49.1 and Z87.1 listed in Safety Standards).
- Wear approved safety glasses with side shields under your helmet.
- Use protective screens or barriers to protect others from flash, glare and sparks; warn others not to watch the arc.
- Wear protective clothing made from durable, flame-resistant material (leather, heavy cotton, or wool) and foot protection.



WELDING can cause fire or explosion.

Welding on closed containers, such as tanks, drums, or pipes, can cause them to blow up. Sparks can fly off from the welding arc. The flying sparks, hot workpiece, and hot equipment can cause fires and burns. Accidental contact of electrode to metal objects can cause sparks, explosion, overheating, or fire. Check and be sure the area is safe before doing any welding.

- Remove all flammables within 35 ft (10.7 m) of the welding arc. If this is not possible, tightly cover them with approved covers.
- Do not weld where flying sparks can strike flammable material.
- Protect yourself and others from flying sparks and hot metal.
- Be alert that welding sparks and hot materials from welding can easily go through small cracks and openings to adjacent areas.
- Watch for fire, and keep a fire extinguisher nearby.
- Be aware that welding on a ceiling, floor, bulkhead, or partition can cause fire on the hidden side.
- Do not weld on closed containers such as tanks, drums, or pipes, unless they are properly prepared according to AWS F4.1 (see Safety Standards).
- Connect work cable to the work as close to the welding area as practical to prevent welding current from traveling long, possibly unknown paths and causing electric shock, sparks, and fire hazards.
- Do not use welder to thaw frozen pipes.
- Remove stick electrode from holder or cut off welding wire at contact tip when not in use.
- Wear oil-free protective garments such as leather gloves, heavy shirt, cuffless trousers, high shoes, and a cap.
- Remove any combustibles, such as a butane lighter or matches, from your person before doing any welding.
- Follow requirements in OSHA 1910.252 (a) (2) (iv) and NFPA 51B for hot work and have a fire watcher and extinguisher nearby.

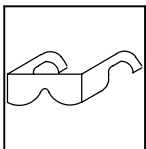

FLYING METAL can injure eyes.

- Welding, chipping, wire brushing, and grinding cause sparks and flying metal. As welds cool, they can throw off slag.
- Wear approved safety glasses with side shields even under your welding helmet.



BUILDUP OF GAS can injure or kill.

- Shut off shielding gas supply when not in use.
- Always ventilate confined spaces or use approved air-supplied respirator.



HOT PARTS can cause severe burns.

- Do not touch hot parts bare handed.
- Allow cooling period before working on gun or torch.
- To handle hot parts, use proper tools and/or wear heavy, insulated welding gloves and clothing to prevent burns.

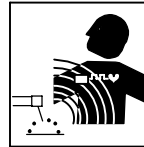

MAGNETIC FIELDS can affect pacemakers.

- Pacemaker wearers keep away.
- Wearers should consult their doctor before going near arc welding, gouging, or spot welding operations.

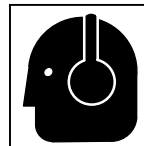

NOISE can damage hearing.

Noise from some processes or equipment can damage hearing.

- Wear approved ear protection if noise level is high.

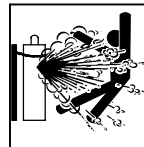

CYLINDERS can explode if damaged.

Shielding gas cylinders contain gas under high pressure. If damaged, a cylinder can explode. Since gas cylinders are normally part of the welding process, be sure to treat them carefully.

- Protect compressed gas cylinders from excessive heat, mechanical shocks, physical damage, slag, open flames, sparks, and arcs.
- Install cylinders in an upright position by securing to a stationary support or cylinder rack to prevent falling or tipping.
- Keep cylinders away from any welding or other electrical circuits.
- Never drape a welding torch over a gas cylinder.
- Never allow a welding electrode to touch any cylinder.
- Never weld on a pressurized cylinder – explosion will result.
- Use only correct shielding gas cylinders, regulators, hoses, and fittings designed for the specific application; maintain them and associated parts in good condition.
- Turn face away from valve outlet when opening cylinder valve.
- Keep protective cap in place over valve except when cylinder is in use or connected for use.
- Use the right equipment, correct procedures, and sufficient number of persons to lift and move cylinders.
- Read and follow instructions on compressed gas cylinders, associated equipment, and Compressed Gas Association (CGA) publication P-1 listed in Safety Standards.

1-3. Additional Symbols For Installation, Operation, And Maintenance



FIRE OR EXPLOSION hazard.

- Do not install or place unit on, over, or near combustible surfaces.
- Do not install unit near flammables.
- Do not overload building wiring – be sure power supply system is properly sized, rated, and protected to handle this unit.

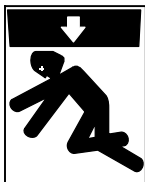

FALLING UNIT can cause injury.

- Use lifting eye to lift unit only, NOT running gear, gas cylinders, or any other accessories.
- Use equipment of adequate capacity to lift and support unit.
- If using lift forks to move unit, be sure forks are long enough to extend beyond opposite side of unit.

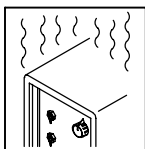

OVERUSE can cause OVERHEATING

- Allow cooling period; follow rated duty cycle.
- Reduce current or reduce duty cycle before starting to weld again.
- Do not block or filter airflow to unit.

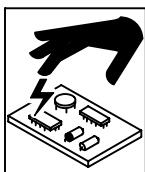

STATIC (ESD) can damage PC boards.

- Put on grounded wrist strap BEFORE handling boards or parts.
- Use proper static-proof bags and boxes to store, move, or ship PC boards.

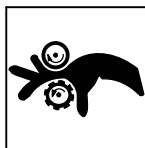

MOVING PARTS can cause injury.

- Keep away from moving parts.
- Keep away from pinch points such as drive rolls.



WELDING WIRE can cause injury.

- Do not press gun trigger until instructed to do so.
- Do not point gun toward any part of the body, other people, or any metal when threading welding wire.



MOVING PARTS can cause injury.

- Keep away from moving parts such as fans.
- Keep all doors, panels, covers, and guards closed and securely in place.
- Have only qualified persons remove doors, panels, covers, or guards for maintenance as necessary.
- Reinstall doors, panels, covers, or guards when maintenance is finished and before re-connecting input power.

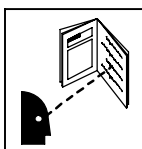

READ INSTRUCTIONS.

- Read Owner's Manual before using or servicing unit.
- Use only genuine Miller/Hobart replacement parts.

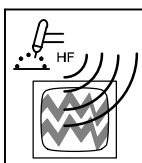

H.F. RADIATION can cause interference.

- High-frequency (H.F.) can interfere with radio navigation, safety services, computers, and communications equipment.
- Have only qualified persons familiar with electronic equipment perform this installation.
- The user is responsible for having a qualified electrician promptly correct any interference problem resulting from the installation.
- If notified by the FCC about interference, stop using the equipment at once.
- Have the installation regularly checked and maintained.
- Keep high-frequency source doors and panels tightly shut, keep spark gaps at correct setting, and use grounding and shielding to minimize the possibility of interference.

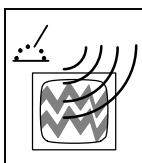

ARC WELDING can cause interference.

- Electromagnetic energy can interfere with sensitive electronic equipment such as computers and computer-driven equipment such as robots.
- Be sure all equipment in the welding area is electromagnetically compatible.
- To reduce possible interference, keep weld cables as short as possible, close together, and down low, such as on the floor.
- Locate welding operation 100 meters from any sensitive electronic equipment.
- Be sure this welding machine is installed and grounded according to this manual.
- If interference still occurs, the user must take extra measures such as moving the welding machine, using shielded cables, using line filters, or shielding the work area.

1-4. California Proposition 65 Warnings

- ▲ **Welding or cutting equipment produces fumes or gases which contain chemicals known to the State of California to cause birth defects and, in some cases, cancer. (California Health & Safety Code Section 25249.5 et seq.)**
- ▲ **Battery posts, terminals and related accessories contain lead and lead compounds, chemicals known to the State of California to cause cancer and birth defects or other reproductive harm. Wash hands after handling.**

For Gasoline Engines:

- ▲ **Engine exhaust contains chemicals known to the State of California to cause cancer, birth defects, or other reproductive harm.**

For Diesel Engines:

- ▲ **Diesel engine exhaust and some of its constituents are known to the State of California to cause cancer, birth defects, and other reproductive harm.**

1-5. Principal Safety Standards

Safety in Welding, Cutting, and Allied Processes, ANSI Standard Z49.1, from Global Engineering Documents (phone: 1-877-413-5184, website: www.global.ihs.com).

Recommended Safe Practices for the Preparation for Welding and Cutting of Containers and Piping, American Welding Society Standard AWS F4.1 from Global Engineering Documents (phone: 1-877-413-5184, website: www.global.ihs.com).

National Electrical Code, NFPA Standard 70, from National Fire Protection Association, P.O. Box 9101, 1 Battery March Park, Quincy, MA 02269-9101 (phone: 617-770-3000, website: www.nfpa.org).

Safe Handling of Compressed Gases in Cylinders, CGA Pamphlet P-1, from Compressed Gas Association, 1735 Jefferson Davis Highway, Suite 1004, Arlington, VA 22202-4102 (phone: 703-412-0900, website: www.cganet.com).

Code for Safety in Welding and Cutting, CSA Standard W117.2, from Canadian Standards Association, Standards Sales, 178 Rexdale

Boulevard, Rexdale, Ontario, Canada M9W 1R3 (phone: 800-463-6727 or in Toronto 416-747-4044, website: www.csa-international.org).

Practice For Occupational And Educational Eye And Face Protection, ANSI Standard Z87.1, from American National Standards Institute, 11 West 42nd Street, New York, NY 10036-8002 (phone: 212-642-4900, website: www.ansi.org).

Standard for Fire Prevention During Welding, Cutting, and Other Hot Work, NFPA Standard 51B, from National Fire Protection Association, P.O. Box 9101, 1 Battery March Park, Quincy, MA 02269-9101 (phone: 617-770-3000, website: www.nfpa.org).

OSHA, Occupational Safety and Health Standards for General Industry, Title 29, Code of Federal Regulations (CFR), Part 1910, Subpart Q, and Part 1926, Subpart J, from U.S. Government Printing Office, Superintendent of Documents, P.O. Box 371954, Pittsburgh, PA 15250 (there are 10 Regional Offices--phone for Region 5, Chicago, is 312-353-2220, website: www.osha.gov).

1-6. EMF Information

Considerations About Welding And The Effects Of Low Frequency Electric And Magnetic Fields

Welding current, as it flows through welding cables, will cause electromagnetic fields. There has been and still is some concern about such fields. However, after examining more than 500 studies spanning 17 years of research, a special blue ribbon committee of the National Research Council concluded that: "The body of evidence, in the committee's judgment, has not demonstrated that exposure to power-frequency electric and magnetic fields is a human-health hazard." However, studies are still going forth and evidence continues to be examined. Until the final conclusions of the research are reached, you may wish to minimize your exposure to electromagnetic fields when welding or cutting.

To reduce magnetic fields in the workplace, use the following procedures:

1. Keep cables close together by twisting or taping them.
2. Arrange cables to one side and away from the operator.
3. Do not coil or drape cables around your body.
4. Keep welding power source and cables as far away from operator as practical.
5. Connect work clamp to workpiece as close to the weld as possible.

About Pacemakers:

Pacemaker wearers consult your doctor before welding or going near welding operations. If cleared by your doctor, then following the above procedures is recommended.

SECTION 2 – INSTALLATION

2-1. Included with Your Unit

- 1 12 ft (3.7 m) Work Cable With Clamp And Quick-Connect
- 2 WP1712SFDI 150 Amp TIG Torch with 12 ft (3.7 m) Cable And Quick-Connect
- 3 Electrode Holder and Quick-Connect
- 4 Gas Hose
- 5 Gas Regulator
- 6 Cable/Torch Hanger
- 7 Foot Pedal Holder
- 8 8 ft (2.4 m) Primary Cord Without Plug
- 9 RFCS-14 Foot Control with 20 ft (6 m) Cable

Some assembly is required.

For options and accessories see back of book or contact your distributor.

804 464-A

2-2. Selecting A Location

Movement

- 1 Lifting Eye
- 2 Lifting Forks

Use lifting eye or lifting forks to move unit.

If using lifting forks, extend forks beyond opposite side of unit.

- 3 Rating Label

Use rating label to determine input power needs (see Section 2-5).

- 4 Line Disconnect Device

Locate unit near correct input power supply.

Position unit so air can circulate.

For information about sources of high-frequency see Section 6.

For carts and caster kits see back of book or contact your distributor.

▲ Special installation may be required where gasoline or volatile liquids are present – see NEC Article 511 or CEC Section 20.

Location And Airflow

18 in (460 mm)

18 in (460 mm)

18 in (460 mm)

18 in (460 mm)

3

4

INPUT SERIAL NO.
STOCK NO.

VOLTS
AMPERES
KW
PHASE HERTZ

2-3. Dimensions And Weights

Dimensions	
Height	30-1/8 in (765 mm)
Width	21-1/8 in (537 mm)
Length	21-1/2 in (546 mm)
A	20 in (508 mm)
B	3/4 in (19 mm)
C	14-3/4 in (375 mm)
D	1 in (25 mm)
E	4 Holes 1/2 in Dia (13 mm)
Weight	
238 lbs (108 kg) 271 lbs (123 kg)*	
* TIGrunner models	

2-4. Specifications

Model	Mode	Rated Output at 40% Duty Cycle	Rated Input, 60 HZ, Single-Phase	KVA	KW	Welding Amperage Range	Max. OCV
208-230	DC TIG	150 Amps at 16 Volts	208-230 V - 45 A - (2)*	10.2 - (0.50)*	4.3 - (0.3)*	5-200	80
	DC Stick	150 Amps at 26 Volts	208-230 V - 47 A - (2)*	10.8 - (0.50)*	5.8 - (0.3)*	5-200	80
	AC TIG**	150 Amps at 16 Volts	208-230 V - 54 A - (2)*	12.3 - (0.50)*	4.5 - (0.3)*	5-200	80
	AC Stick	150 Amps at 26 Volts	208-230 V - 54 A - (2)*	12.4 - (0.50)*	6 - (0.3)*	5-200	80
460	DC TIG	150 Amps at 16 Volts	460 V - 22 A - (1)*	10.2 - (0.50)*	4.3 - (0.3)*	5-200	80
	DC Stick	150 Amps at 26 Volts	460 V - 25 A - (1)*	10.8 - (0.50)*	5.8 - (0.3)*	5-200	80
	AC TIG**	150 Amps at 16 Volts	460 V - 28 A - (1)*	12.3 - (0.50)*	4.5 - (0.3)*	5-200	80
	AC Stick	150 Amps at 26 Volts	460 V - 28 A - (1)*	12.4 - (0.50)*	6 - (0.3)*	5-200	80
575	DC TIG	150 Amps at 16 Volts	575 V - 19 A - (.5)*	10.2 - (0.50)*	4.3 - (0.3)*	5-200	80
	DC Stick	150 Amps at 26 Volts	575 V - 20 A - (.5)*	10.8 - (0.50)*	5.8 - (0.3)*	5-200	80
	AC TIG**	150 Amps at 16 Volts	575 V - 22 A - (.5)*	12.3 - (0.50)*	4.5 - (0.3)*	5-200	80
	AC Stick	150 Amps at 26 Volts	575 V - 22 A - (.5)*	12.4 - (0.50)*	6 - (0.3)*	5-200	80

* () While idling.

** Input amperage with AC Balance control in the balanced position. Input amperage may be higher with control in an unbalanced position.

2-5. Rating Labels

208-230 Volt					460/575 Volt						
		10A/13V		200A/18V				10A/13V		200A/18V	
		X	10%	40%	100%			X	10%	40%	100%
		I_2	200	150	90			I_2	200	150	90
$U_o=80V$		U_2	18	16	14.0	$U_o=80V$		U_2	18	16	14.0
		10A/20.5V		200A/28V				10A/20.5V		200A/28V	
		X	10%	40%	100%			X	10%	40%	100%
		I_2	200	150	90			I_2	200	150	90
$U_o=80V$		U_2	28	26	24	$U_o=80V$		U_2	28	26	24
		$U_1=230V$		$I_1=54A$				$U_1=460V$		$I_1=28A$	
1~60 Hz						1~60 Hz		$U_2=575V$		$I_2=22A$	

2-6. Duty Cycle Chart

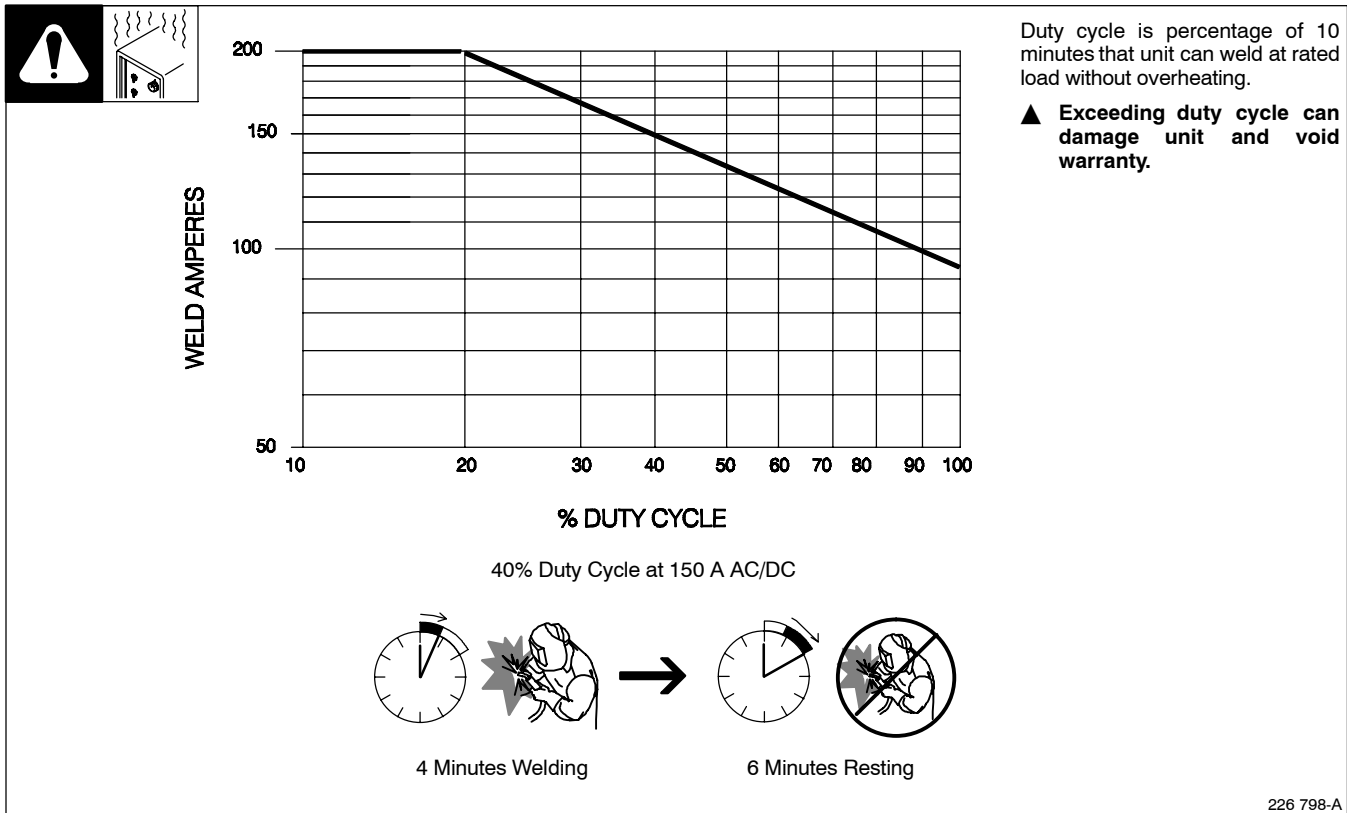

226 798-A

2-7. DC Volt-Ampere Curves

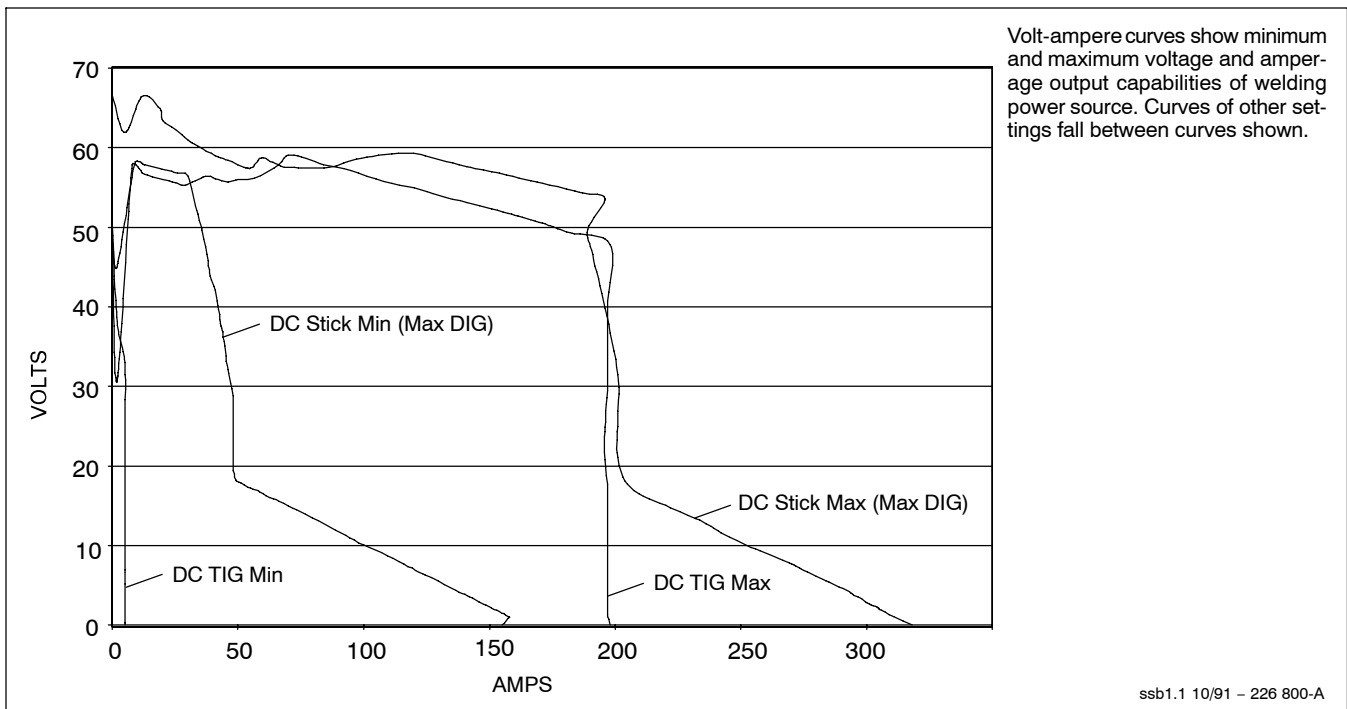

2-8. AC Volt-Ampere Curves

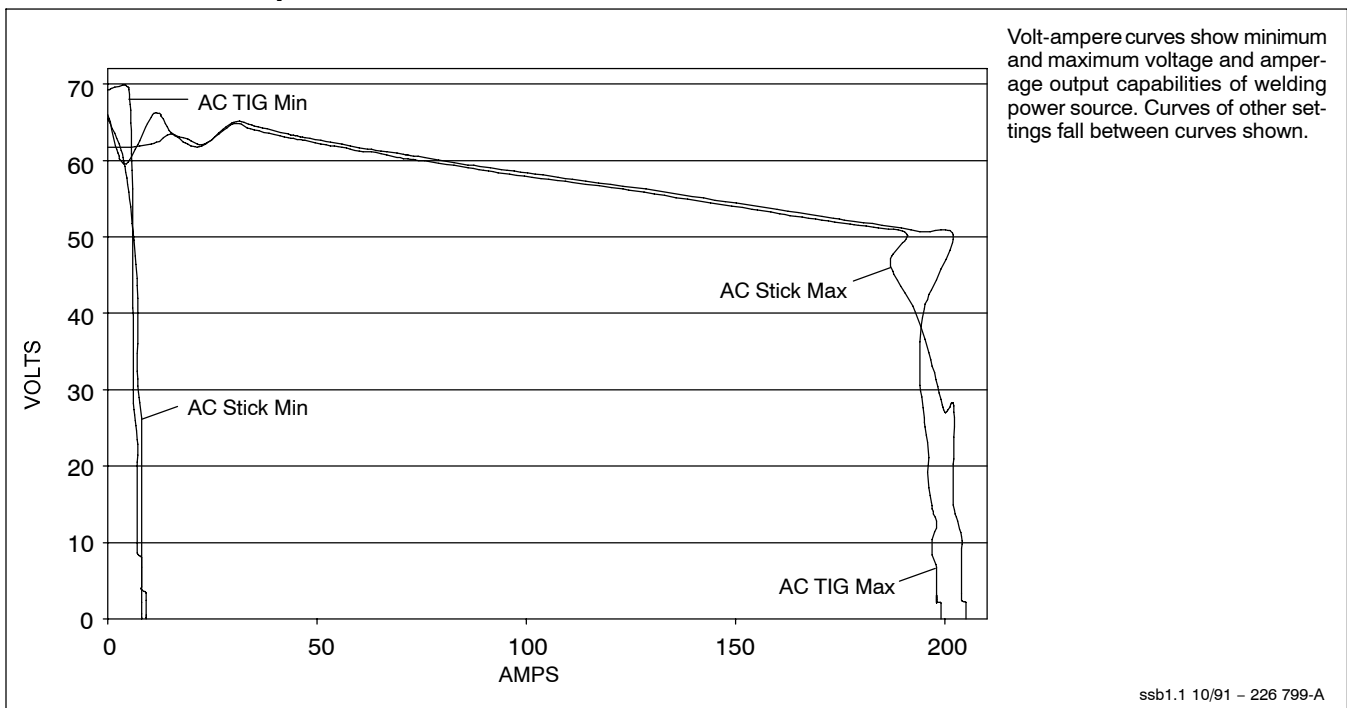

2-9. Weld Output Terminals And Selecting Cable Sizes



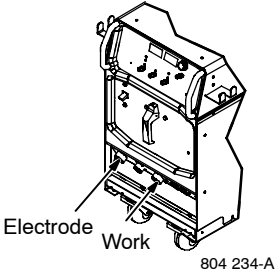

▲ ARC WELDING can cause Electromagnetic Interference.

To reduce possible interference, keep weld cables as short as possible, close together, and down low, such as on the floor. Locate welding operation 100 meters from any sensitive electronic equipment. Be sure this welding machine is installed and grounded according to this manual. If interference still occurs, the user must take extra measures such as moving the welding machine, using shielded cables, using line filters, or shielding the work area.

 <p>Weld Output Terminals</p> <p>▲ Turn off power before connecting to weld output terminals.</p> <p>▲ Do not use worn, damaged, undersized, or poorly spliced cables.</p>	Total Cable (Copper) Length In Weld Circuit Not Exceeding									
	100 ft (30 m) Or Less		150 ft (45 m)	200 ft (60 m)	250 ft (70 m)	300 ft (90 m)	350 ft (105 m)	400 ft (120 m)		
	Welding Amperes	10 – 60% Duty Cycle	60 – 100% Duty Cycle	10 – 100% Duty Cycle						
	100	4	4	4	3	2	1	1/0	1/0	
	150	3	3	2	1	1/0	2/0	3/0	3/0	
	200	3	2	1	1/0	2/0	3/0	4/0	4/0	
	250	2	1	1/0	2/0	3/0	4/0	2-2/0	2-2/0	

Weld cable size (AWG) is based on either a 4 volts or less drop or a current density of at least 300 circular mils per ampere. S-0007-D

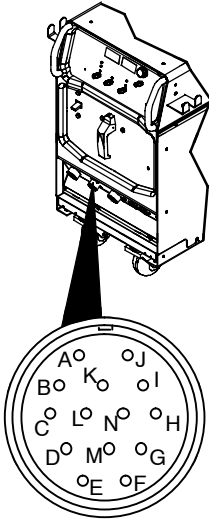
2-10. Remote 14 Receptacle

		Socket*	Socket Information		
	A		A	15 volts DC.	
		A	A	B	Contact closure to A completes 15 volts DC contactor control circuit.
				C	Command reference; 0 to +10 volts DC output to remote control.
				D	Remote control circuit common.
				E	0 to +10 volts DC input command signal from remote control.
				K	Chassis common.

*The remaining sockets are not used.

2-11. 115 Volts AC Duplex Receptacle And Supplementary Protector CB1

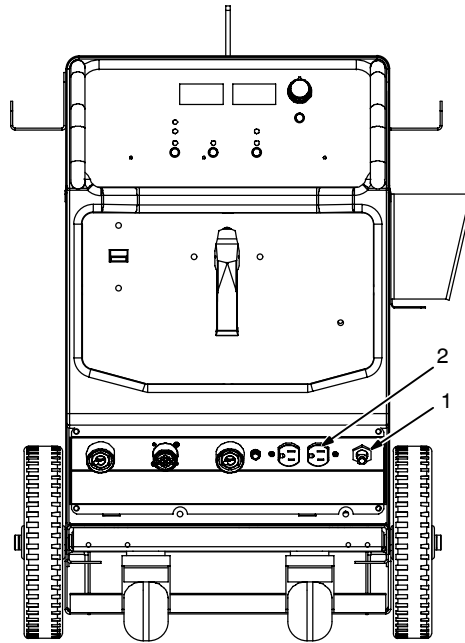

▲ **Turn Off power before connecting to receptacle or resetting protector.**

1 Supplementary Protector CB1
If CB1 opens, high frequency and output to the 115 volts ac duplex receptacle stop. Press button to reset protector.

2 115 V 15 Amp AC Receptacle
Provides 115 volts, 15 amps of ac power for equipment such as grinders, drills, coolers, etc.. Receptacle is protected from overload by supplementary protector CB1.

804 267-B

2-12. Shielding Gas Connections

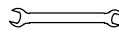

Tools Needed:

 5/8, 1-1/8 in

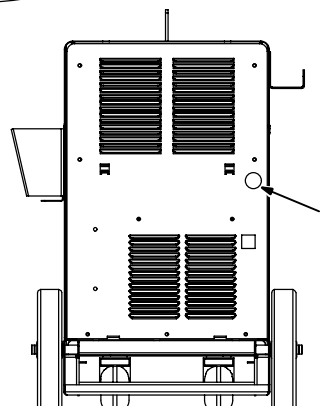
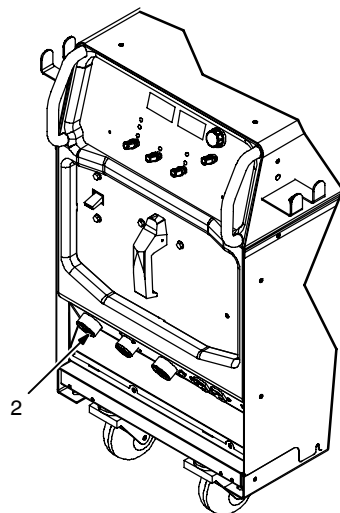
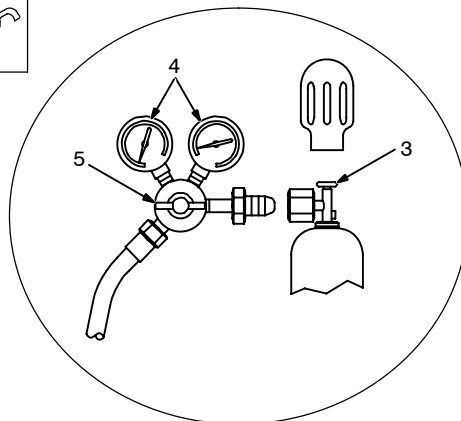

▲ **Turn Off power before connecting to receptacle.**

1 Gas Valve In Fitting
Fitting has 5/8-18 right-hand threads.
Located on rear of unit.

2 Gas Valve Out Fitting

Gas connection is integrated into the Electrode weld output terminal by means of a flow-through type connector.

3 Cylinder Valve

Open valve slightly so gas flow blows dirt from valve. Close valve.

4 Regulator/Flow Gauge

Connect regulator/flow gauge to gas cylinder.

Connect gas hose to gas in fitting.

5 Flow Adjust

Typical flow rate is 20 cfh (cubic feet per hour).

804 234-B / 804 235-B

2-13. Typical TIG Connections

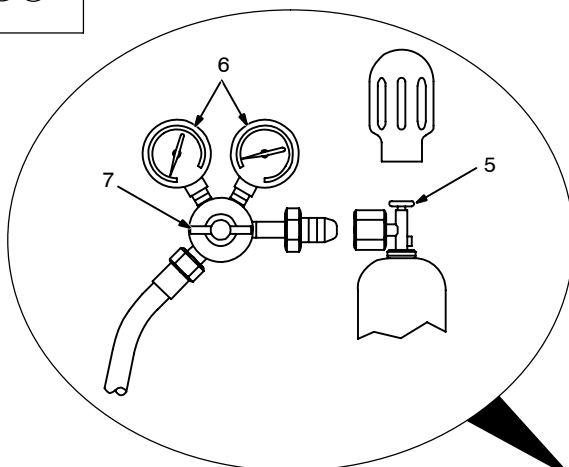

Tools Needed:

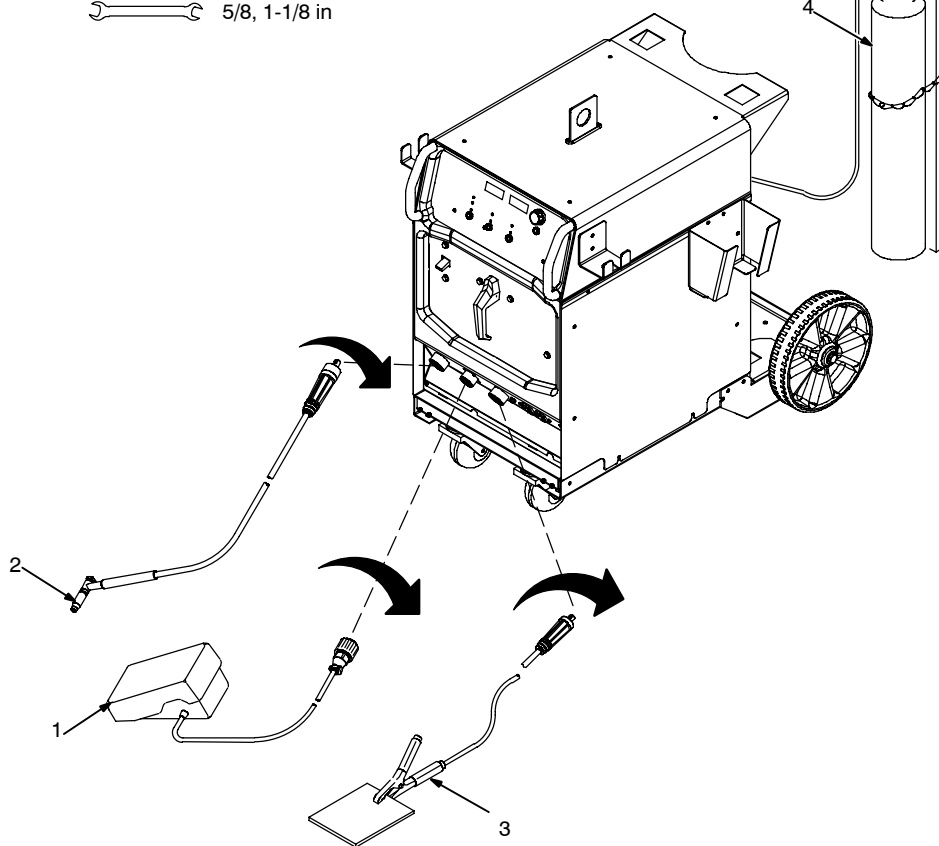
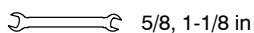

▲ Turn off power before making connections.

- 1 Remote Foot Control

A customer supplied remote fingertip control may also be used.

- 2 Torch
- 3 Work Clamp

Connect remote control, torch, and work clamp to receptacles as shown.

- 4 Cylinder

Chain or secure cylinder to running gear, wall, or other stationary support.

- 5 Cylinder Valve

Open valve slightly so gas flow blows dirt from valve. Close valve.

- 6 Regulator/Flow Gauge

Install so face is vertical.

- 7 Flow Adjust

Typical flow rate is 20 cfm (cubic feet per hour) (9.4 L/min).

NOTE: After activating remote control, 0.2 seconds of gas preflow will begin.

Preflow Application:

Preflow is used to purge the immediate weld area of atmosphere. Preflow also aids in consistent arc starting. Preflow is preset and is not adjustable.

Post Flow Application:

Postflow is required to cool tungsten and weld, and to prevent contamination of tungsten and weld. Increase postflow time if tungsten or weld are dark in appearance (see Section 3-8).

2-14. Typical Stick Connections

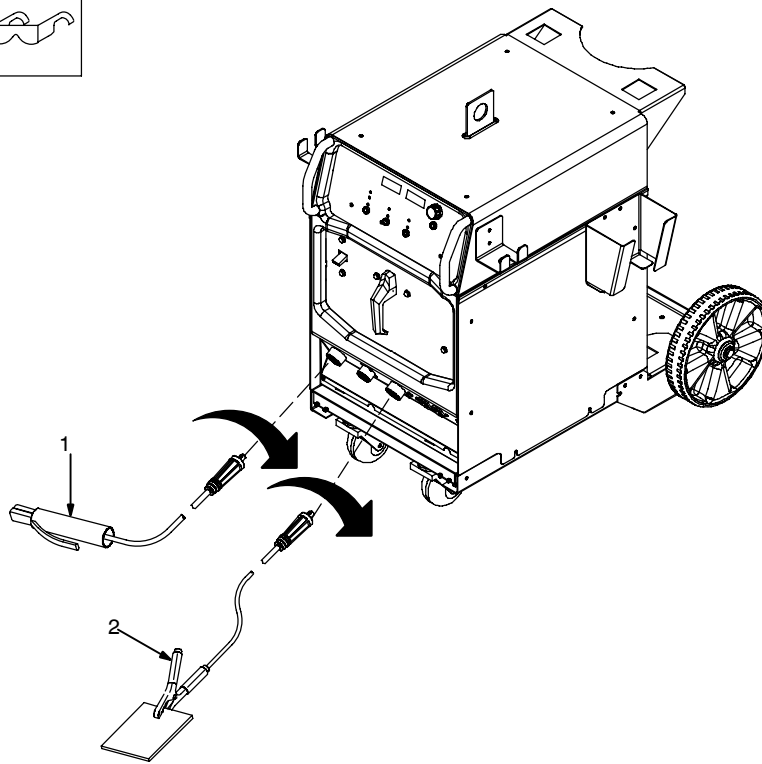

▲ Turn off power before making connections.

- 1 Electrode Holder
- 2 Work Clamp

Connect electrode holder and work clamp to receptacles as shown.

2-15. Electrical Service Guide

NOTE

All values calculated at 40% duty cycle.

NOTE

Actual input voltage cannot exceed $\pm 10\%$ of indicated required input voltage shown in table. If actual input voltage is outside of this range, damage to unit may occur.

50/60 Hz Single Phase				
Input Voltage	208-230	460	575	
Input Amperes At Rated Output	54	27	22	
Max Recommended Standard Fuse or circuit breaker Rating In Amperes ¹	Time-Delay ²			
		60	30	25
	Normal Operating ³	80	40	30
Min Input Conductor Size In AWG ⁴	8	12	14	
Max Recommended Input Conductor Length In Feet (Meters)	147 (45)	249 (76)	256 (78)	
Min Grounding Conductor Size In AWG ⁴	8	12	14	

Reference: 2005 National Electrical Code (NEC)

1 Consult factory for circuit breaker applications.

2 "Time-Delay" fuses are UL class "RK5".

3 "Normal Operating" (general purpose - no intentional delay) fuses are UL class "K5" (up to and including 60 amp), and UL class "H" (65 amp and above).

4 Conductor data in this section specifies conductor size (excluding flexible cord or cable) between the panelboard and the equipment per NEC Table 310.16. If a flexible cord or cable is used, minimum conductor size may increase. See NEC Table 400.5(A) for flexible cord and cable requirements.

2-16. Connecting Input Power In 208–230 Volt Models

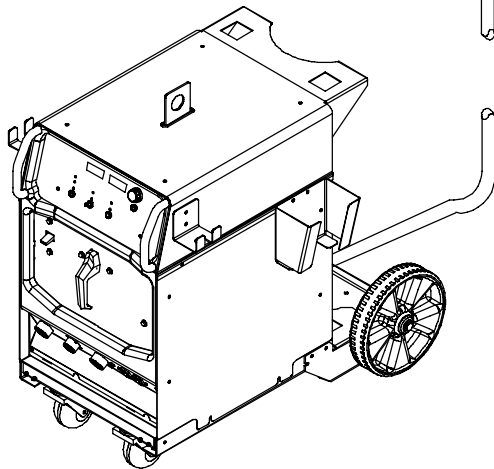
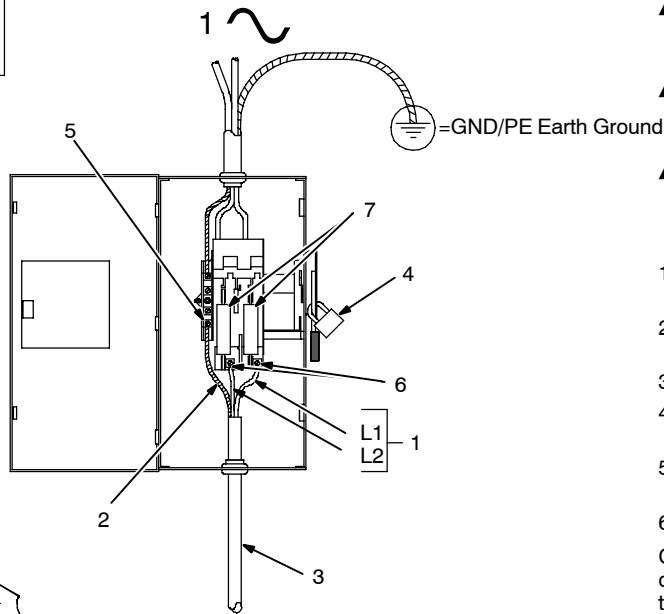

Tools Needed:

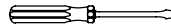

▲ Installation must meet all National and Local Codes – have only qualified persons make this installation.

▲ Disconnect and lockout/tagout input power before connecting input conductors from unit.

▲ Always connect green or green/yellow conductor to supply grounding terminal first, and never to a line terminal.

1 Black And White Input Conductor (L1 And L2)

2 Green Or Green/Yellow Grounding Conductor

3 Input Power Cord.

4 Disconnect Device (switch shown in the OFF position)

5 Disconnect Device Grounding Terminal

6 Disconnect Device Line Terminals

Connect green or green/yellow grounding conductor to disconnect device grounding terminal first.

Connect input conductors L1 and L2 to disconnect device line terminals.

7 Over-Current Protection

Select type and size of over-current protection using Section 2-15 (fused disconnect switch shown).

Close and secure door on disconnect device. Remove lockout/tagout device, and place switch in the On position.

804 234-B / Ref. 803 766-B

2-17. Connecting Input Power In 460/575 Volt Models

A. Placing Jumper Links

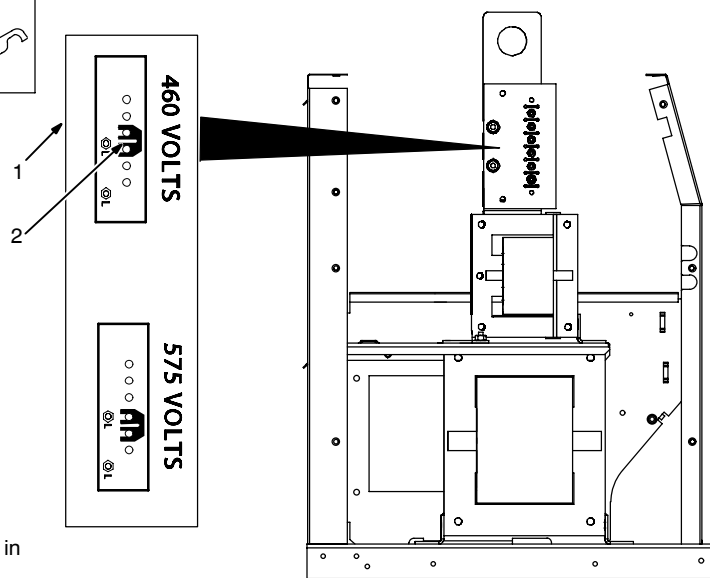

Tools Needed:



▲ Disconnect and lockout/tagout input power before installing or moving jumper links.

Check input voltage available at site.

Remove cover and left side panel.

1 Jumper Link Label

2 Jumper Links

Move jumper links to match input voltage.

Install left side panel and cover, or go on to Section B.



Ref. 804 470-A

B. Connecting Input Power In 460/575 Volt Models

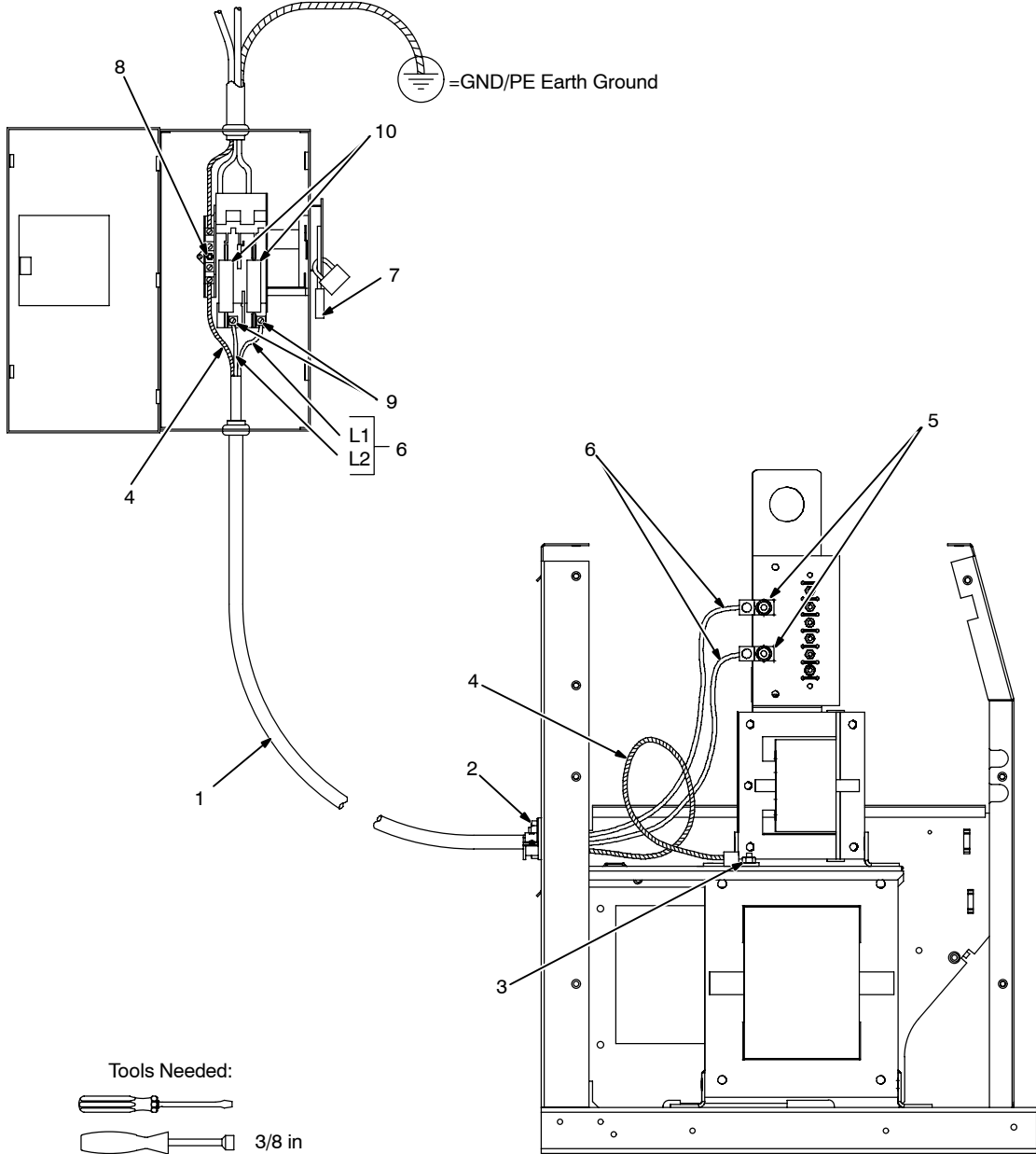

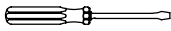

Tools Needed:

 3/8 in

▲ Installation must meet all National and Local Codes – have only qualified persons make this installation.

▲ Disconnect and lockout/tagout input power before connecting input conductors from unit.

▲ Make input power connections to the welding power source first.

▲ Always connect green or green/yellow conductor to supply grounding terminal first, and never to a line terminal.

See rating label on unit and check input voltage available at site.

1 Input Power Conductors (Customer Supplied Cord)

Select size and length of conductors using Section 2-15. Conductors must comply with national, state, and local electrical codes. If applicable, use lugs of proper amperage capacity and correct hole size.

Welding Power Source Input Power Connections

2 Strain Relief

Route conductors (cord) through strain relief and tighten screws.

3 Machine Grounding Terminal

4 Green Or Green/Yellow Grounding Conductor

Connect green or green/yellow grounding conductor to welding power source grounding terminal first.

5 Welding Power Source Line Terminals

6 Input Conductors L1 And L2

Connect input conductors L1 and L2 to welding power source line terminals.

Install panels and wrapper on welding power source.

Disconnect Device Input Power Connections

7 Disconnect Device (switch shown in OFF position)

8 Disconnect Device (Supply) Grounding Terminal

Connect green or green/yellow grounding conductor to disconnect device grounding terminal first.

9 Disconnect Device Line Terminals

Connect input conductors L1 and L2 to disconnect device line terminals.

10 Overcurrent Protection

Select type and size of overcurrent protection using Section 2-15 (fused disconnect switch shown).

Close and secure door on line disconnect device. Remove lockout/tagout device, and place switch in the On position.

804 470-A

SECTION 3 – OPERATION

3-1. Controls

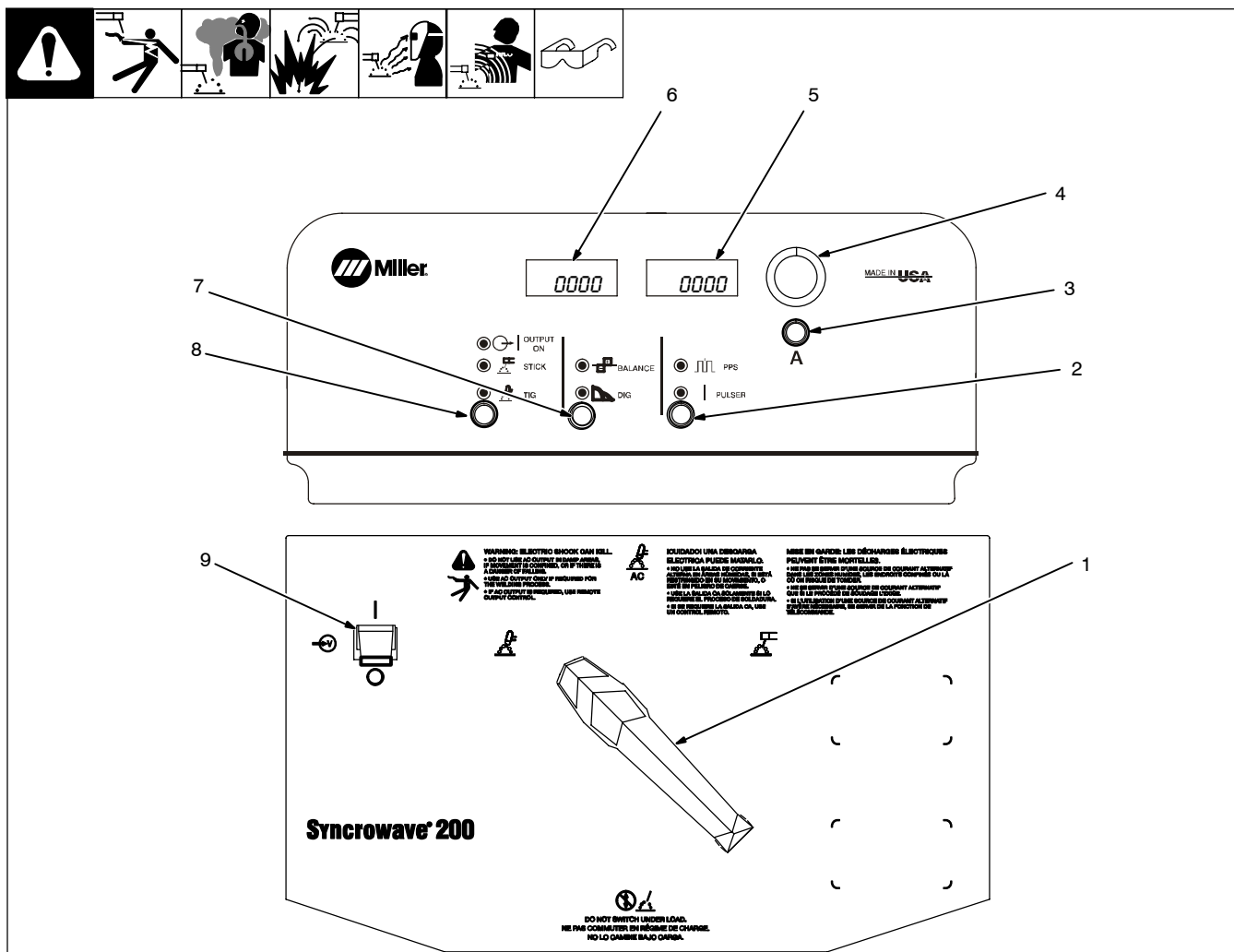

228 528-A / 221 123-A

1 Output Selector Switch (Polarity)

▲ **Do not use AC output in damp areas, if movement is confined, or if there is danger of falling. Use AC output ONLY if required for the welding process, and then use a remote control.**

▲ **Do not change position of switch while welding or while under load.**

Use switch to select Direct Current Electrode Negative (DCEN), AC, or Direct Current Electrode Positive (DCEP) output without changing weld output cable connections.

2 Pulse Push Button Control
See Section 3-5.

3 Main Amps Push Button (Amperage Control)
See Section 3-3.

4 Encoder Adjustment Control

Use control in conjunction with applicable front panel function switch to set values for that function.

5 Ammeter And Parameter Adjust
See Section 3-2.

6 Voltmeter And Parameter Adjust
See Section 3-2.

7 Adjust Push Button Control

See Section 3-6.

8 Process Push Button Control
See Section 3-4.

9 Power Switch

Use switch to turn unit On and Off.

3-2. Ammeter, Voltmeter And Parameter Display

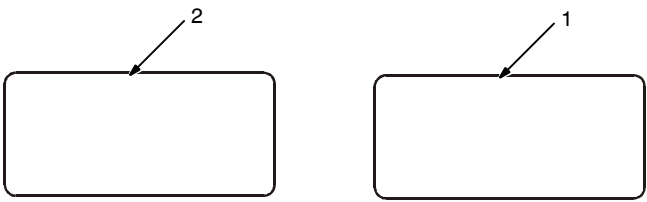

1 Ammeter
Displays actual amperage while welding. Meter also displays preset parameters for any of the following units of measure when they are active: amperage, time, percentage or frequency.

2 Voltmeter
Displays output or open-circuit voltage while output is on. Meter also displays preset parameters.

3-3. Amperage Control

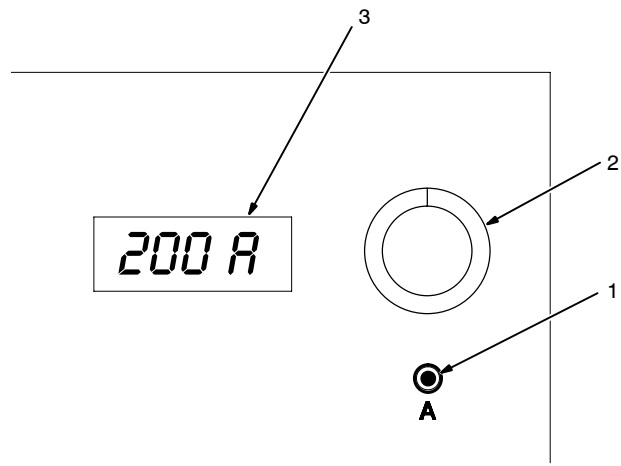

1 Main Amps Push Button (Amperage Control)
2 Encoder Adjustment Control
3 Ammeter

See Section 3-7 for Amperage range.

Press Main Amps push button, and turn Encoder control to set weld amperage. Weld amperage setting is also peak amperage when Pulser function is active (see Section 3-5).

3-4. Process Control

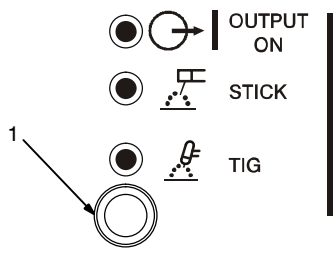

1 Process Control
Press Process button until desired process LED is illuminated:

TIG - When selected, an HF (non-contact) arc starting method is activated. Weld output is not available until a remote control is activated. This method can be used with either AC or DC TIG welding. Make connections according to Section 2-13.

▲ Weld output terminals are energized when power is on, and Output On LED is lit.

Stick (SMAW) - When Stick is selected, weld output is on, terminals are energized, and output LED is lit. This method can be used with either AC or DC Stick welding. Make connections according to Section 2-14.

3-5. Pulse Control

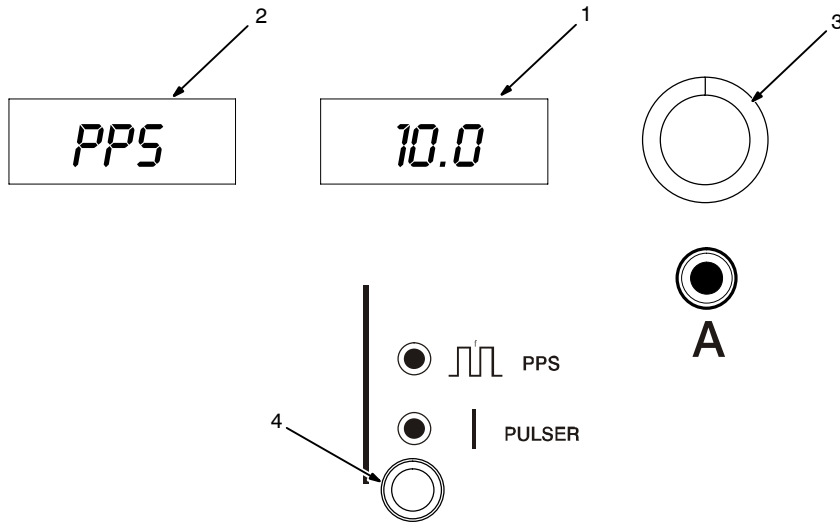

- 1 Ammeter
- 2 Voltmeter
- 3 Encoder Adjustment Control
- 4 Pulse Control

Pulsing is available only while using the TIG process, it cannot be selected if the Stick process (see Section 3-4) is active. Controls can be adjusted while welding.

Press Pulse push button to activate pulser function.

ON - When illuminated, this LED indicates the pulser is on.

Turn Encoder to set pulses per second. See Section 3-7 for Pulse parameters. The selected pulse value is displayed on the ammeter, and [PPS] is displayed on the voltmeter as long as the pulse function is active.

Press Pulse control button to turn pulse function off.

Press Main Amps or Adjust control button to exit pulse control screen and leave pulser activated.

Application:

Pulsed TIG welding involves switching the weld output between a high or peak amperage, and a low or background amperage at a controlled rate of pulses per second.

Pulsing the weld output from a higher peak amperage, to a lower background amperage, lowers the average welding amperage, which can reduce heat input and improve weld puddle control.

Set the number of pulses per second based on the application. Pulsing rates of 1 to 2 pps can improve the timing and amount of filler metal that are added to the weld puddle, improving weld bead consistency. Filler metal should be dipped, or added to the weld puddle when the output pulses to the high, or peak amperage.

Fast pulsing rates can improve the bead appearance of welds made without filler, or allow filler to be continuously added to the weld puddle without any dipping action. The pulse rate should be adjusted along with travel speed to obtain desired weld bead appearance.

3-6. Balance/DIG Control

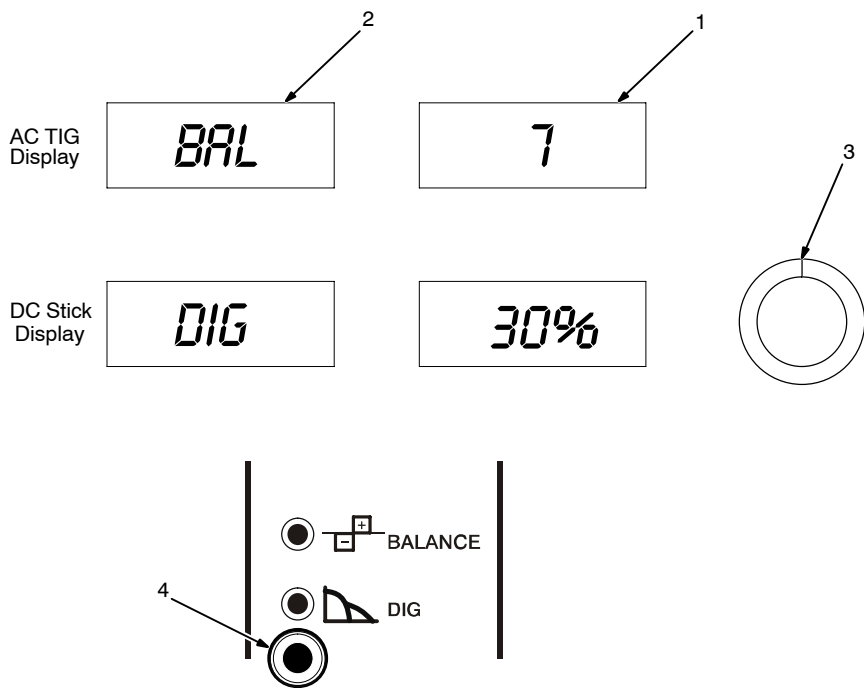

- 1 Ammeter
- 2 Voltmeter
- 3 Encoder Adjustment Control
- 4 Adjust Control

Select desired process, AC TIG or DC Stick (see Section 3-4).

Press Adjust push button to turn Balance/DIG function and LED on.

If **AC TIG** is selected, turn encoder control to select appropriate balance value (see Section 3-7). The selected value is displayed on the ammeter, and [BAL] is displayed on the voltmeter.

Balance changes the AC squarewave output. Set control to 7 and adjust as necessary (see Balance Control Examples). Set at a higher value to decrease the arc cleaning (or etching) zone and increase penetration, or set at a lower value to increase arc cleaning action of the workpiece.

Application:

Joint configuration, set-up, process variables, and oxide thickness may affect setting.

▲ Do not use AC output in damp areas, if movement is confined, or if there is a danger of falling. Use AC output only if required for the welding process.

AC weld output is preferred for aluminum due to the oxide cleaning action it provides. AC balance controls the amount of cleaning action which should be adjusted according to how heavy or thick the surface oxides are.

Adjust ac balance to the highest setting that provides approximately 0.10 in (2.5 mm) of etching zone along the weld toes, while maintaining a clear, shiny weld puddle.

AC balance should be decreased if a distinct etching zone is not visible near the weld toes, or if the weld puddle appears to have dark, pepper-like spots on the surface.

If **DC Stick** is selected, turn encoder control to select the appropriate amount of Dig (see Section 3-7). The selected value is displayed on the ammeter, and [DIG] is displayed on the voltmeter.

When set at 0, the DIG current will provide no additional short-circuit amperage at low arc voltage. Increasing the DIG percentage increases the short circuit amperage at a low arc voltage to help start and maintain an arc and prevent the electrode from sticking to the workpiece.

Application:

Increase the DIG percentage to reduce or prevent the electrode from sticking to the workpiece.

- For cellulose electrodes (6010, 6011), use a DIG setting of 50 to 80%.
- For low hydrogen electrodes (7018), use a DIG setting of 20 to 35%.
- For other electrodes, set DIG high enough to prevent electrode sticking.
- Setting DIG too high could result in burn thru and unwanted digging due to excessive short circuit current.

Balance Control Examples		
Setting	Output Waveforms	Arc
Typical Starting Point BAL 7	43% Electrode Positive 57% Electrode Negative	
More Penetration BAL 10	40% Electrode Positive 60% Electrode Negative	

3-7. Factory Parameter Defaults And Range And Resolution

Parameter	Default	Range And Resolution
PROCESS	TIG HF	TIG HF, STICK
A MAIN / PEAK		
AC	150 A	5 – 200 Amps
DC	150 A	5 – 200 Amps
PULSER	Off	ON / OFF
PPS	10 PPS	0.1–15 PPS
PEAK t	50%	20 – 80 Percent
BKGND A	50%	5 – 95 Percent
POSTFLOW	Auto	5 - 50 Amps: 5 Seconds 51 - 200 Amps: Adds 1 Second Per 10 Amps
	Manual:	1 -25 Seconds
DIG	30%	0 – 100 Percent
BALANCE	7	1–10
TIG HF Syncro-Start™ Settings		
AC	Med	Soft/Med/Hot
DC	Med	Soft/Med/Hot

3-8. Postflow Control

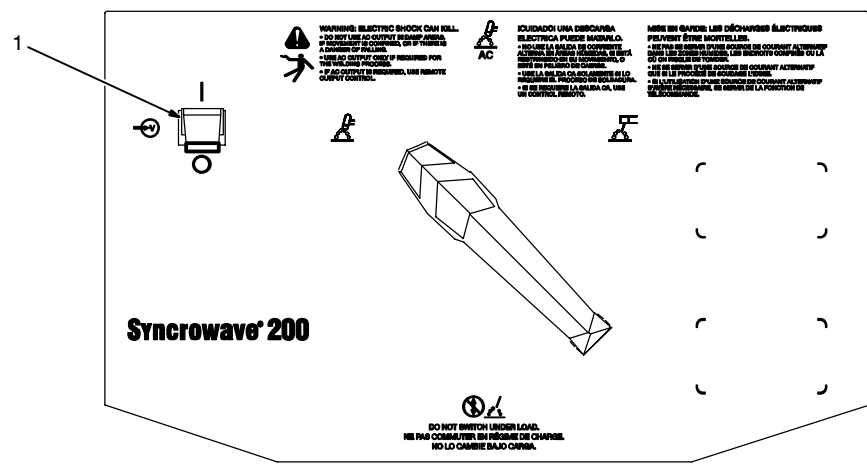
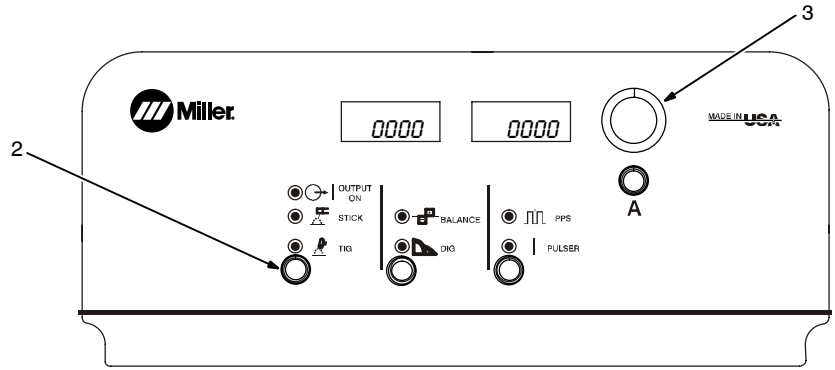

Postflow time is automatically controlled. Auto-postflow provides a minimum of five seconds of post-flow for anything less than 50 amps of weld current, and an additional one second of postflow for each additional ten amps of weld current.

- 1 Power Switch
- 2 Process Control
- 3 Encoder Adjust Control

To override auto-postflow and set a specific postflow time, press and hold Process push button while turning on power. Hold button for approximately 7 seconds. Voltmeter will display *POST*, and ammeter will display *AUTO*. Turn encoder to set desired time in seconds. Postflow settings effects AC and DC TIG, and is not polarity specific. Press torch trigger or turn off power to save settings.

Application:

Auto-postflow time is optimally set based on weld amperage. This amount of auto-postflow time provides adequate shielding with no manual adjustment. The use of auto-postflow at low amperages avoids excessive postflow times and a waste of shielding gas. See Section 3-7 for postflow parameters.

3-9. Selecting Syncro Start Characteristics

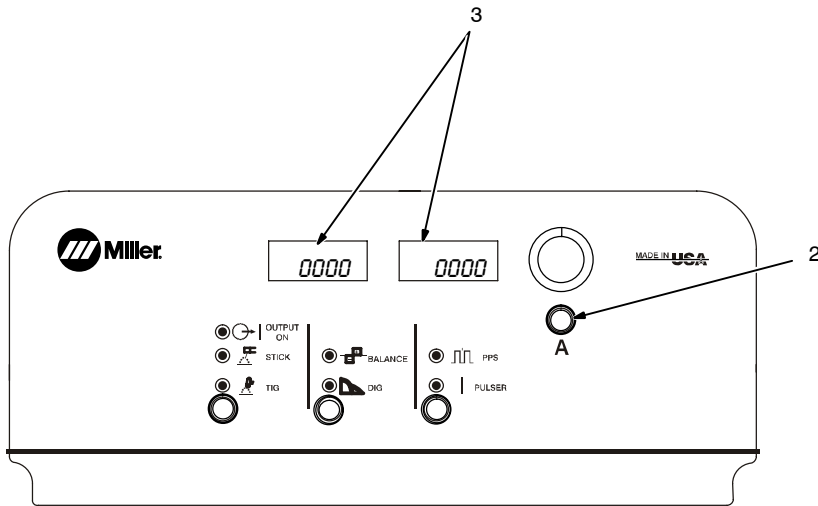

- 1 Power Switch
- 2 Main Amps Control
- 3 Volt And Ammeters
- 4 Process Selector Switch

To change TIG HF Syncro starting characteristics, turn Off power, place Output Selector switch in desired position, DCEN, DCEP or AC. Each position has three start characteristics options. Push and hold Main Amps button and turn on power. Hold button for approximately 7 seconds.

Meters will display [AC] [MED] or [DCEP] [MED], or [DCEP] [MED], depending on position of Output Selector switch

Turn Encoder to step through the three start characteristics choices. Ammeter displays active choice: soft start, medium start, or hot start.

Change polarity (see Section 3-1) to set values for each TIG output. Each setting is polarity specific.

Press torch trigger or turn off power to save settings.

Application:

Soft start - use for thin gauge material and small diameter tungstens (.040-1/16 in)

Medium start - factory default, used for most welding applications with 1/16, 3/32 and 1/8 in tungstens.

Hot start - use for thick materials with a large diameter tungsten (1/8-5/32 in).

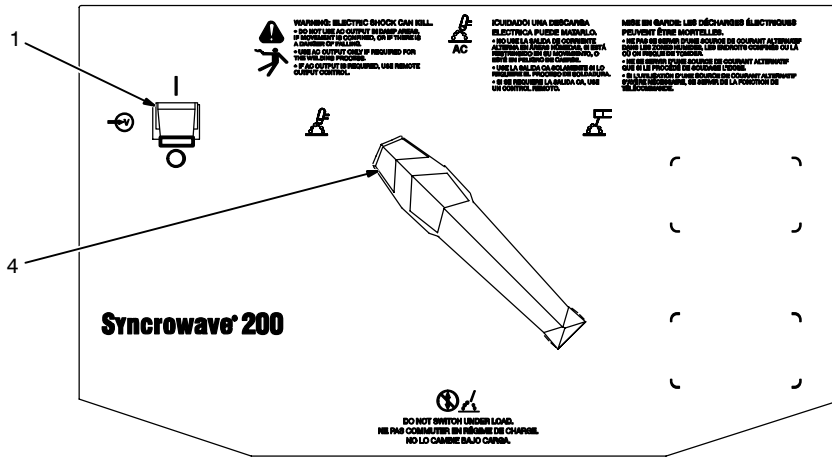

3-10. Pulsar Peak And Background

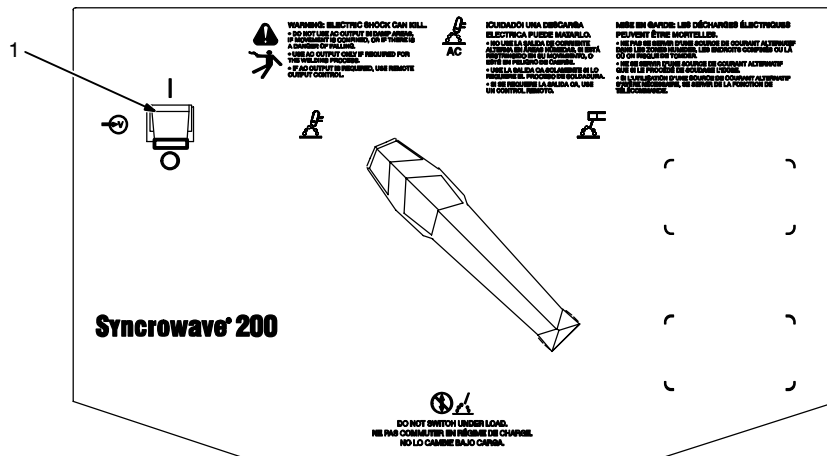
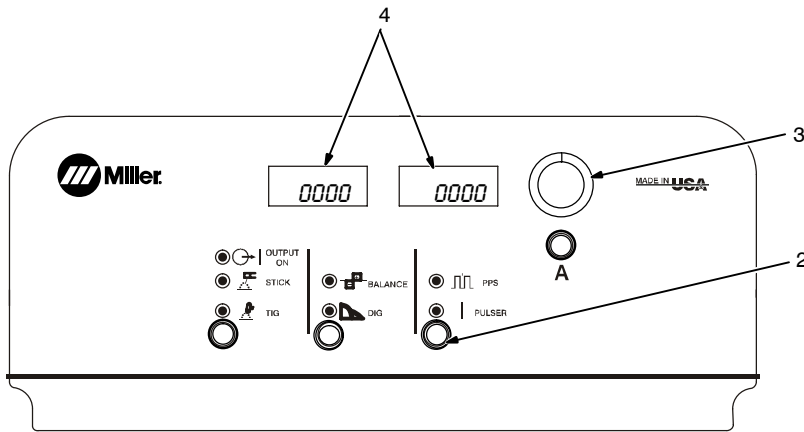

- 1 Power Switch
 - 2 Pulse Control
- Push and hold Pulsar button and turn on power. Hold button for approximately 7 seconds.

- 3 Encoder Control
 - 4 Volt And Ammeter
- Press Pulse button to cycle parameters (see Section 3-7 for parameter ranges).

PPS (Pulses Per Second or Pulse Frequency) is used to determine appearance of weld bead (See Section 3-5).

PEAK t [PKT] [50%]- The percentage of each pulse cycle that can be spent at the peak amperage level.

BKGD A [BKA] [50%] - (Background Amps) - Use Background Amps to set the low pulse of the weld amperage, which cools the weld puddle and affects overall heat input. Background Amps is set as a percentage of peak amperage.

Turn encoder to select appropriate value for active pulse parameter. Value selected is shown on the ammeter.

5 Pulsed Output Waveforms

Example shows affect changing the Peak Time control has on the pulsed output waveform.

NOTE: Peak amperage is set using the Main Amps push button control (see Section 3-3), or with a remote control. Peak amperage is the highest welding amperage allowed to occur in the pulse cycle. Weld penetration varies directly with peak amperage.

Application:

Pulsed TIG welding involves switching the weld output between a high or peak amperage, and a low or background amperage at a controlled rate (see Section 3-5). The raised portions of the weld output are controlled in width, height, and frequency, forming pulses of weld output. These pulses and the lower amperage level between them (called the background amperage) alternately heat and cool the molten weld puddle. The combined effect gives the operator better control of penetration, bead width, crowning, undercutting, and heat input. Controls can be adjusted while welding.

Pulsing can also be used for filler material addition technique training.

Percent (%) Peak Time Control Setting	Pulsed Output Waveforms
Balanced (50%)	
More Time At Peak Amperage (80%)	
More Time At Background Amperage (20%)	

3-11. Timer/Cycle Counter

1 Power Switch

2 Process Control

3 Pulse Control

4 Timer Display

5 Cycle Display

To read timer/cycle counter, press and hold the Process and Pulse buttons, and turn power on.

The hours are displayed for five seconds, and then the minutes are displayed for five seconds.

The cycles are displayed for the next five seconds, and are read as 12,345,678 cycles.

3-12. Software Number/Revision

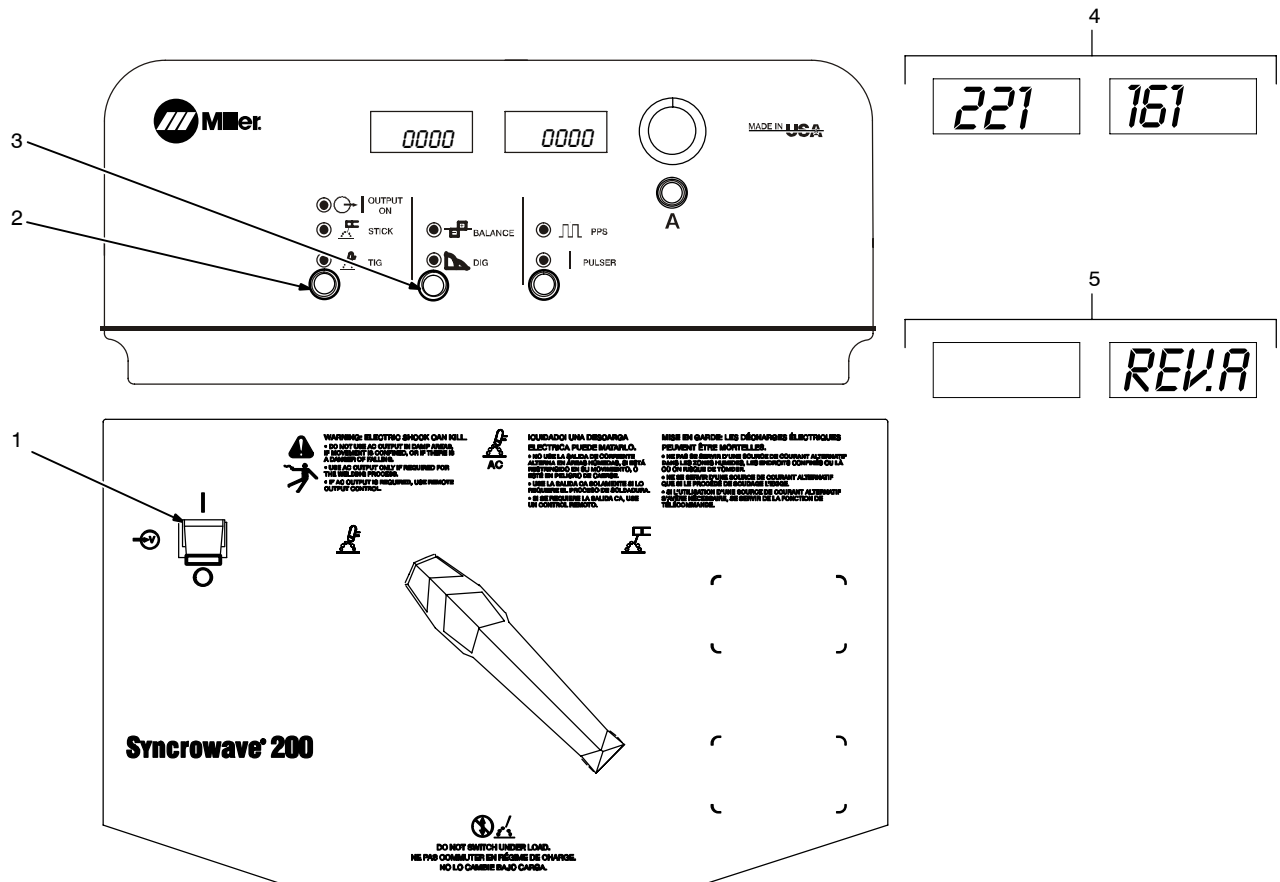

- 1 Power Switch
- 2 Process Control
- 3 Adjust Control

To read software number/revision, press

and hold the Process and Adjust buttons,

4 Software Number Display

The software number is displayed for five



seconds.

5 Revision Display

The revision is displayed for the next five seconds.

SECTION 4 – MAINTENANCE AND TROUBLESHOOTING

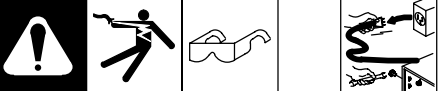
4-1. Routine Maintenance

 **▲ Disconnect power before maintaining.**
 *Maintain more often during severe conditions.*

 **3 Months**

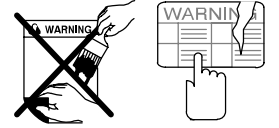
Replace unreadable labels. 

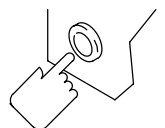
Replace o-ring in Electrode/Gas Output receptacle if cracked. 

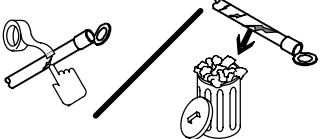
Repair or replace cracked weld cable. 

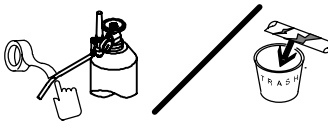
Repair or replace cracked gas hose. 

 **6 Months**

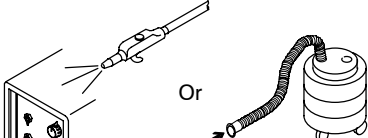
Blow out or vacuum inside. 

4-2. Adjusting Spark Gaps



▲ Disconnect and lockout/tagout input power before adjusting spark gaps.

Remove right side panel.

Tools Needed:

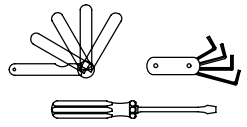

1 Tungsten End Of Point

2 Spark Gap

3 Adjustment Screws

4 Pressure Point

Normal spark gap is 0.008 in (0.203 mm).

If adjustment is needed, proceed as follows:

Loosen screws. Place gauge of proper thickness in spark gap.

Apply slight pressure at point until gauge is held firmly in gap. Tighten screws to 12 in/lbs torque. Adjust other gap.

Reinstall right side panel.

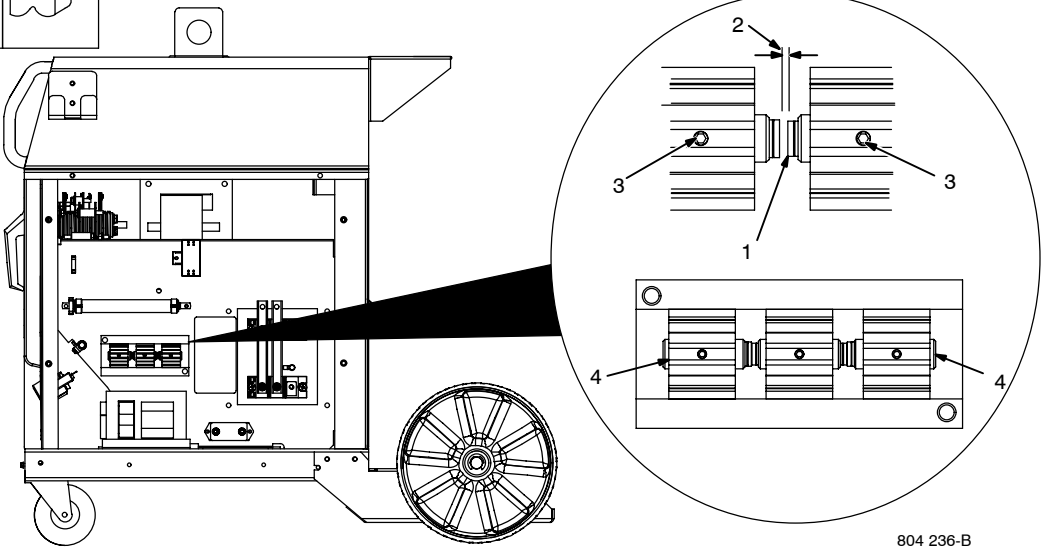

804 236-B

4-3. Voltmeter/Ammeter Help Displays

All directions are in reference to the front of the unit. All circuitry referred to is located inside the unit.

1 Help 0 Display

Indicates a short in the thermal protection circuitry located on the transformer of the unit. If this display is shown, contact a Factory Authorized Service Agent.

2 Help 1 Display

An SCR overcurrent condition has occurred. Turn power off and back on to correct condition. If problem continues, contact a Factory Authorized Service Agent.

3 Help 2 Display

Indicates an open in the thermal protection circuitry located on the transformer of the unit. If this display is shown, contact a Fac-

tory Authorized Service Agent.

4 OVER TEMP XFMR

Indicates the transformer of the unit has overheated. The unit has shut down to allow the fan to cool it (see Section 2-6). Operation will continue when the unit has cooled.

5 Help 4 Display

Indicates an open in the thermal protection circuitry located on the rectifier assembly of the unit. If this display is shown, contact a Factory Authorized Service Agent.

6 OVER TEMP RECT

Indicates the rectifier assembly of the unit has overheated. The unit has shut down to allow the fan to cool it (see Section 2-6). Op-

eration will continue when the unit has cooled.

7 Help 6 Display

Indicates a short in the thermal protection circuitry located on the rectifier assembly of the unit. If this display is shown, contact a Factory Authorized Service Agent.

8 REL RMT

Indicates Remote Output control is activated. Release Remote Output control to clear help message.

9 POL ERR

Indicates Output Selector switch is not in correct position (see Section 3-1).

10 NOT VALID

Indicates a non-allowable set-up on the front panel.

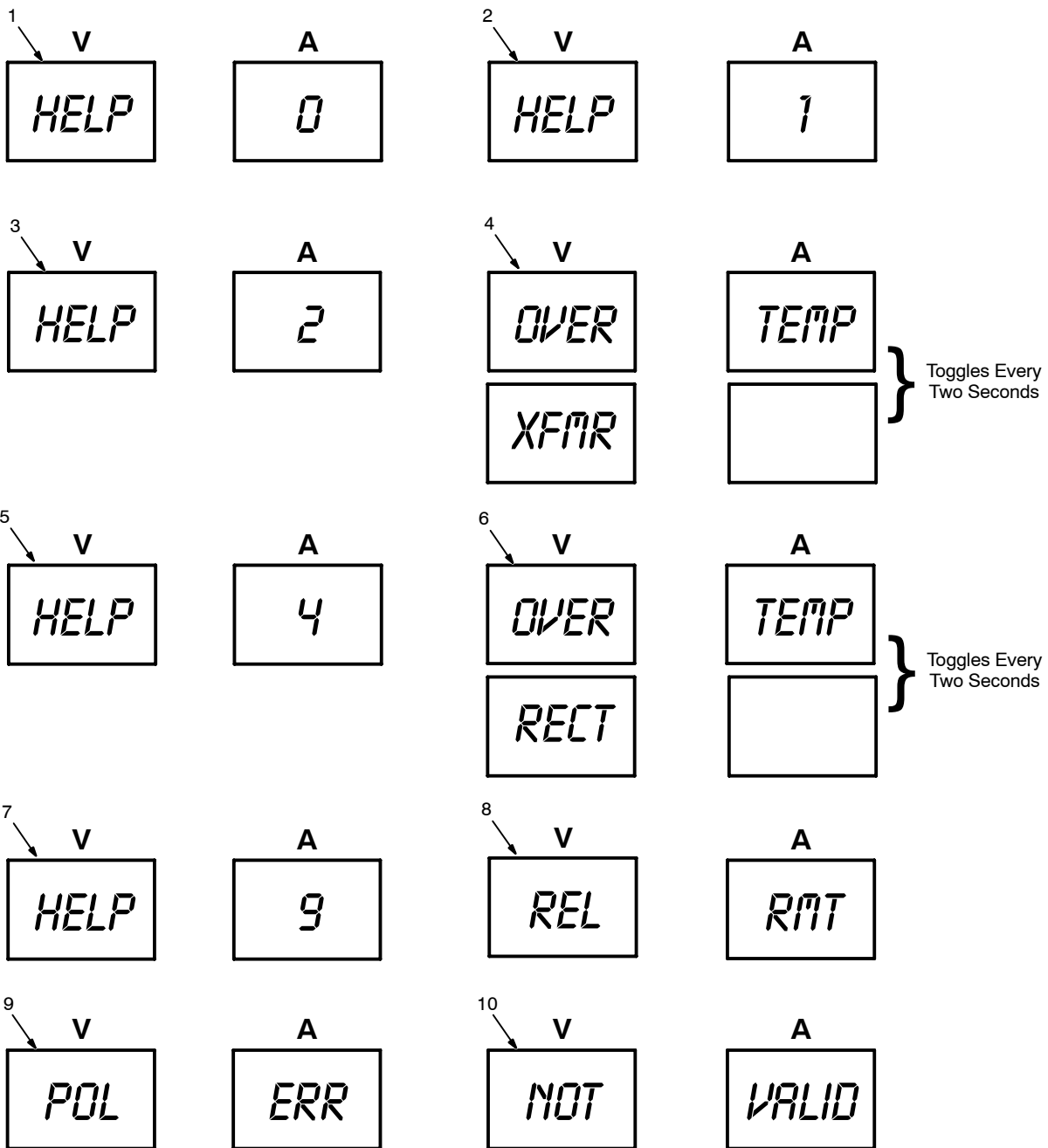

4-4. Troubleshooting

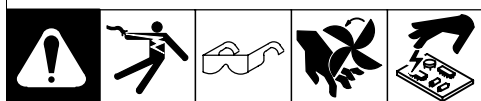

NOTE: The remedies listed below are recommendations only. If these remedies do not fix the trouble with your unit, have a Factory Authorized Service Agent check unit.
There are no user serviceable parts inside unit.

Refer to Section 4-3 for any Help (HLP) message displayed on voltmeter/ammeter.

Trouble	Remedy
No weld output; unit completely inoperative.	Place machine power switch in On position (see Section 3-1).
	Place line disconnect switch in On position (see Section 2-16).
	Check and replace line fuse(s), if necessary (see Section 2-16).
	Check for proper input power connections (see Section 2-16).
No weld output; unit on.	Check, repair, or replace remote control.
	Have Factory Authorized Service Agent check unit.
Unit provides only maximum or minimum weld output.	Make sure Amperage control is in proper position (see Section 3-1).
	Have Factory Authorized Service Agent check unit.
Erratic or improper weld output.	Use proper size and type of weld cable (see Section 2-9).
	Clean and tighten all weld connections.
	Lay weld cables out straight, do not leave weld cables coiled.
	Check position of Output Selector control (see Section Figure 3-1).
	If using remote control, check position of Amperage Adjustment control (see Section 3-1).
No control of weld output.	Make sure Amperage control is in proper position (see Section 3-1).
Lack of high frequency; difficulty in starting GTAW arc.	Select proper size tungsten (see Section 7-1).
	Be sure torch cable is not close to any grounded metal.
	Check cables and torch for cracked insulation or bad connections. Repair or replace.
	Check spark gaps (see Section 4-2).
Wandering arc – poor control of direction of arc.	Reduce gas flow rate (see Section 2-13).
	Select proper size tungsten (see Section 7-1).
	Properly prepare tungsten (see Section 7-2).
Tungsten electrode oxidizing and not remaining bright after conclusion of weld.	Shield weld zone from drafts.
	Increase postflow time (see Section 3-8).
	Check and tighten all gas fittings.
	Properly prepare tungsten (see Section 7-2).
Fan not operating.	Unit equipped with Fan-On-Demand™. Fans run only when necessary. Unit equipped with circuitry to protect against overheating.
No weld output; fan does not run.	Place line disconnect switch in On position (see Section 2-16).
	Check and replace line fuse(s), if necessary, or reset circuit breaker (see Section 2-16).
	Check for proper input power connections (see Section 2-16).
No weld output; fan on.	Be sure Output Selector switch is not set between positions (see Section 3-1).
	Tighten remote control connection to Remote 14 receptacle (see Section 2-10).
	Check remote control (see remote control Owner's Manual).
	Unit overheated. Allow unit to cool (see Section 2-6).
Fan not operating; weld output available.	Check for and remove anything blocking fan movement.
	Have Factory Authorized Service Agent check fan motor.

SECTION 5 - ELECTRICAL DIAGRAM

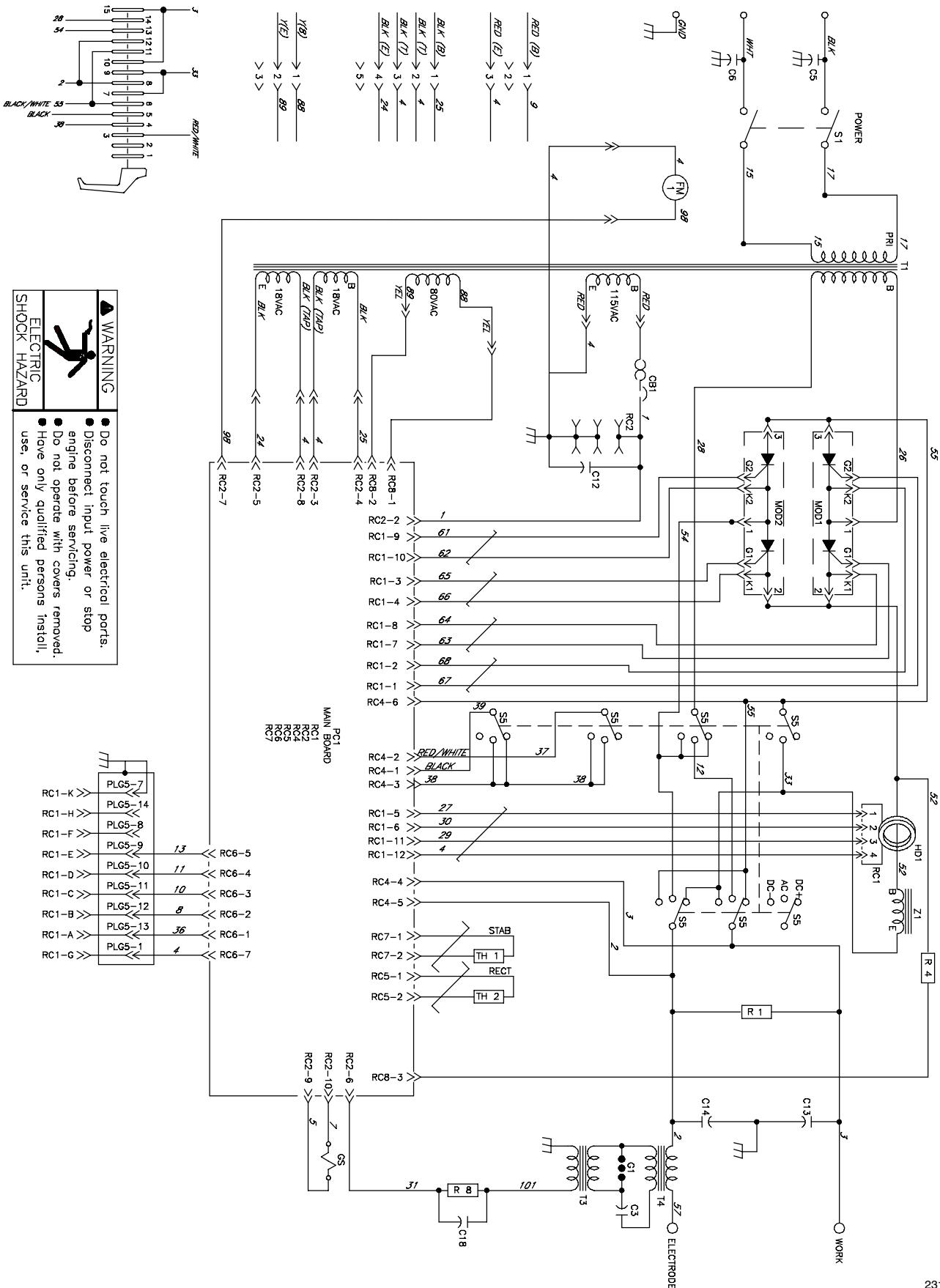
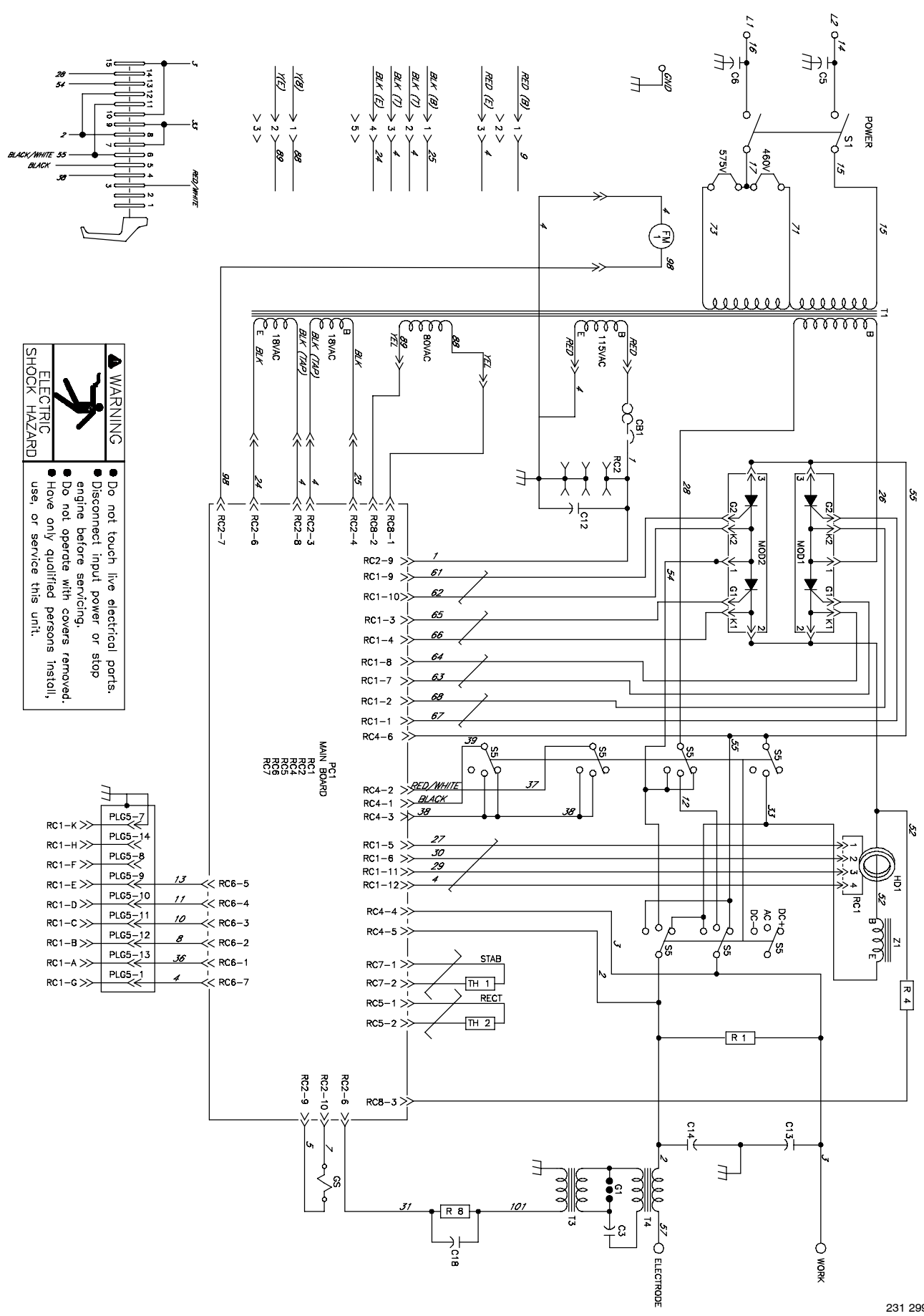

Figure 5-1. Circuit Diagram For 208-230 Volt Models

231 276-A



WARNING

Do not touch live electrical parts.
 Disconnect input power or stop engine before servicing.
 Do not operate with covers removed.
 Have only qualified persons install, use, or service this unit.

ELECTRIC SHOCK HAZARD

Figure 5-2. Circuit Diagram For 460/575 Volt Models

231 299-A

SECTION 6 – HIGH FREQUENCY

6-1. Welding Processes Requiring High Frequency



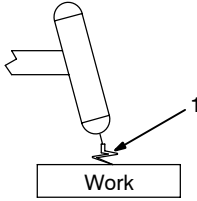

TIG

1 High-Frequency Voltage

TIG – helps arc jump air gap between torch and workpiece and/or stabilize the arc.

high_freq 7/05 – S-0693

6-2. Incorrect Installation



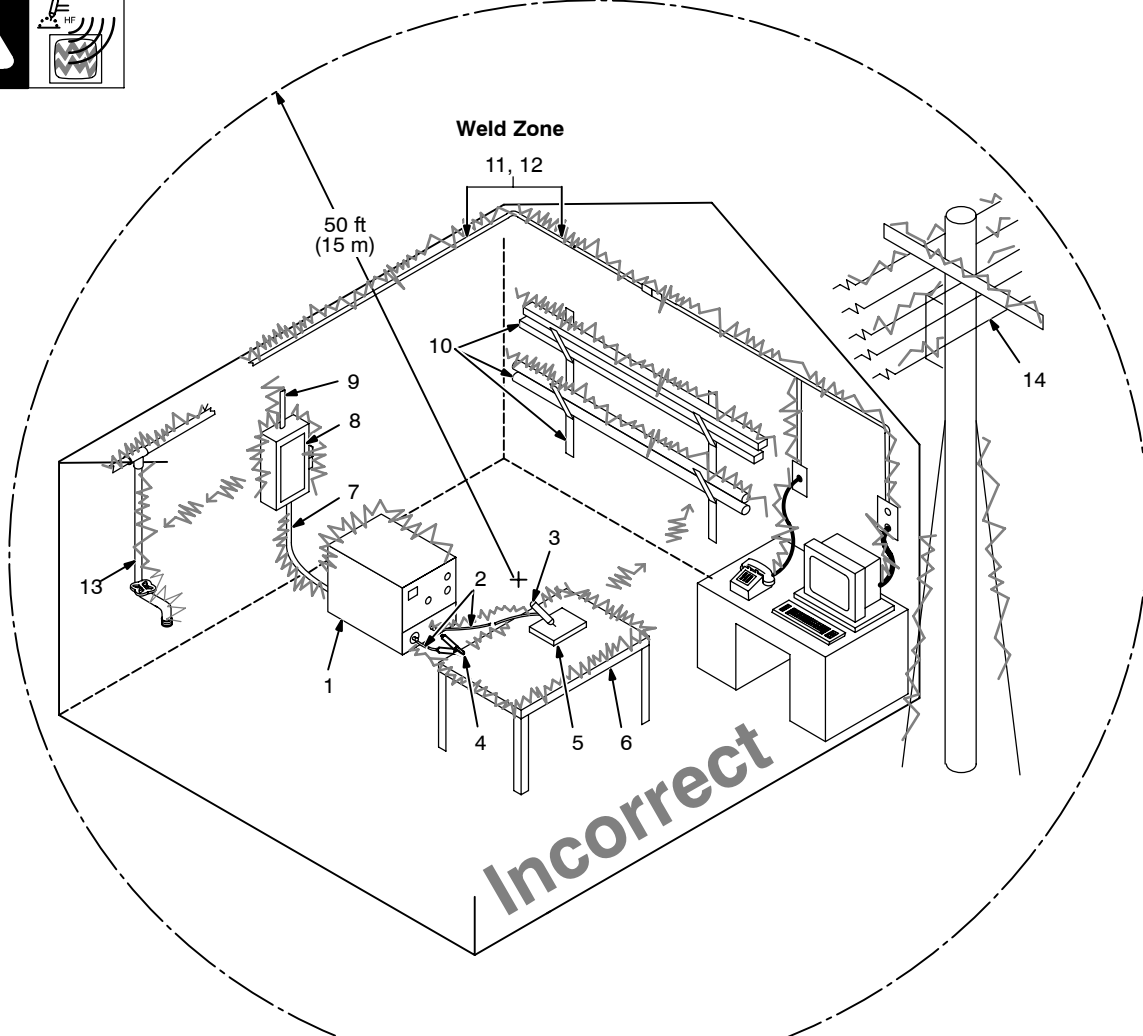

Sources of Direct High-Frequency Radiation	Sources of Conduction of High Frequency	Sources of Reradiation of High Frequency
1 High-Frequency Source (welding power source with built-in HF or separate HF unit)	7 Input Power Cable	10 Ungrounded Metal Objects
2 Weld Cables	8 Line Disconnect Device	11 Lighting
3 Torch	9 Input Supply Wiring	12 Wiring
4 Work Clamp		13 Water Pipes and Fixtures
5 Workpiece		14 External Phone and Power Lines
6 Work Table		

S-0694

6-3. Correct Installation

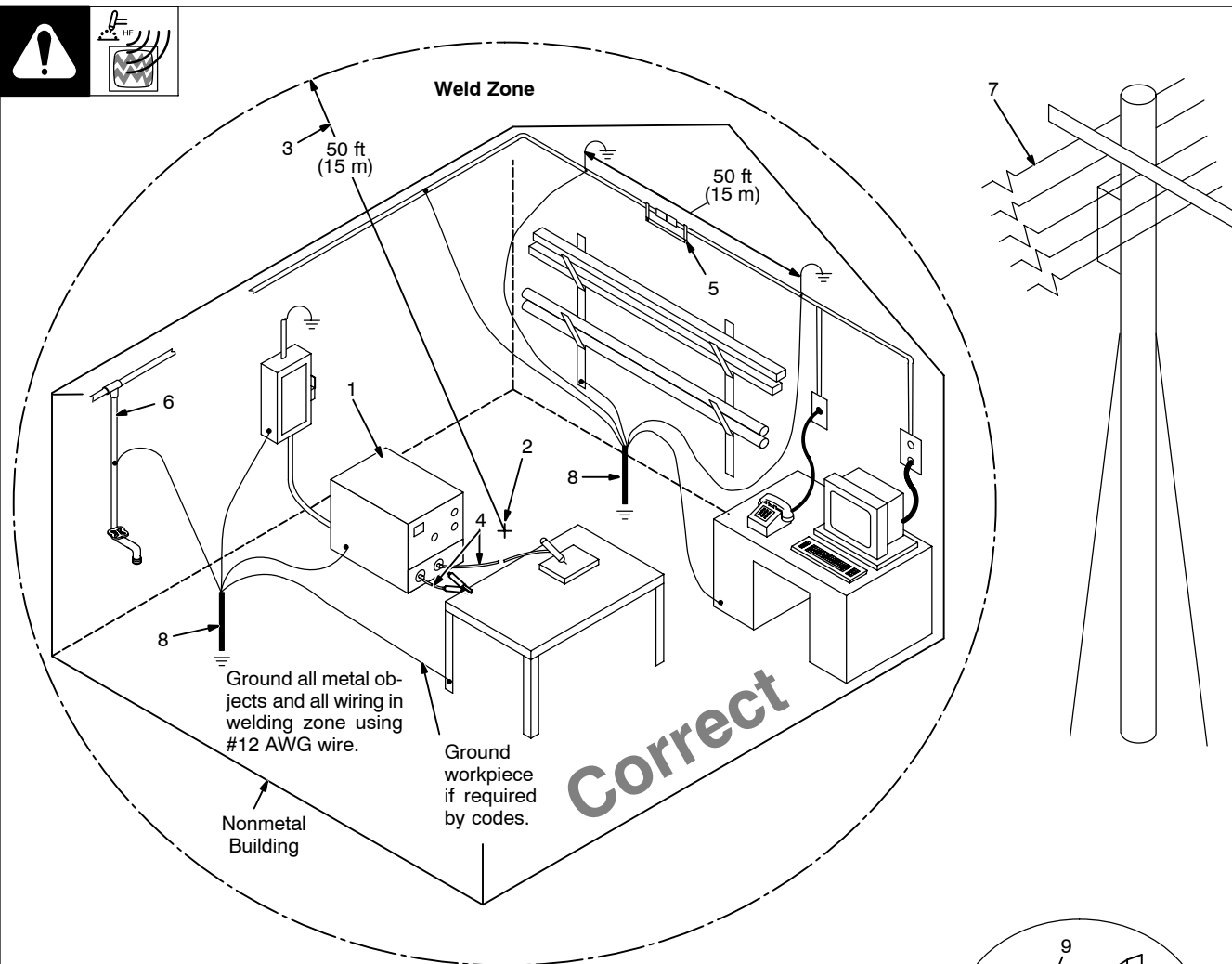

Ground all metal objects and all wiring in welding zone using #12 AWG wire.

Ground workpiece if required by codes.

Nonmetal Building

Correct

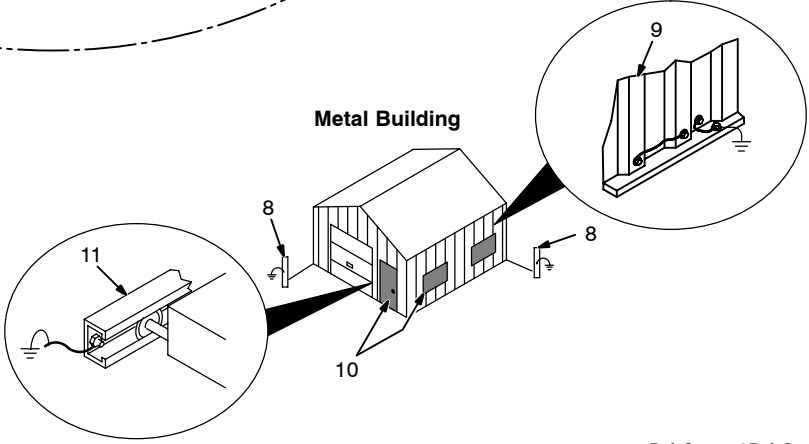

Ref. S-0695 / Ref. S-0695

- 1 High-Frequency Source (welding power source with built-in HF or separate HF unit)
Ground metal machine case, work output terminal, line disconnect device, input supply, and worktable.
- 2 Center Point of Welding Zone
Midpoint between high-frequency source and welding torch.
- 3 Welding Zone
A circle 50 ft (15 m) from center point in all directions.
- 4 Weld Output Cables
Keep cables short and close together.

- 5 Conduit Joint Bonding and Grounding
Electrically join (bond) all conduit sections using copper straps or braided wire. Ground conduit every 50 ft (15 m).
- 6 Water Pipes and Fixtures
Ground water pipes every 50 ft (15 m).
- 7 External Power or Telephone Lines
Locate high-frequency source at least 50 ft (15 m) away from power and phone lines.
- 8 Grounding Rod
Consult the National Electrical Code for specifications.

- Metal Building Requirements**
- 9 Metal Building Panel Bonding Methods
Bolt or weld building panels together, install copper straps or braided wire across seams, and ground frame.
 - 10 Windows and Doorways
Cover all windows and doorways with grounded copper screen of not more than 1/4 in (6.4 mm) mesh.
 - 11 Overhead Door Track
Ground the track.

SECTION 7 – SELECTING AND PREPARING TUNGSTEN ELECTRODE FOR DC OR AC WELDING

ac/dc_gtaw 2/2000



▲ Whenever possible and practical, use DC weld output instead of AC weld output.

7-1. Selecting Tungsten Electrode (Wear Clean gloves To Prevent Contamination Of Tungsten)

Electrode Diameter	Amperage Range - Gas Type♦ - Polarity			
	DC – Argon – Electrode Negative/Straight Polarity	DC – Argon – Electrode Positive/Reverse Polarity	AC – Argon	AC – Argon – Balanced Wave
2% Ceria (Orange Band), 1.5% Lanthanum (Gray Band), Or 2% Thorium (Red Band) Alloy Tungstens				
.010"	Up to 25	*	Up to 20	Up to 15
.020"	15-40	*	15-35	5-20
.040"	25-85	*	20-80	20-60
1/16"	50-160	10-20	50-150	60-120
3/32"	135-235	15-30	130-250	100-180
1/8"	250-400	25-40	225-360	160-250
5/32"	400-500	40-55	300-450	200-320
3/16"	500-750	55-80	400-500	290-390
1/4"	750-1000	80-125	600-800	340-525
Pure Tungsten (Green Band)				
.010"	Up to 15	*	Up to 15	Up to 10
.020"	5-20	*	5-20	10-20
.040"	15-80	*	10-60	20-30
1/16"	70-150	10-20	50-100	30-80
3/32"	125-225	15-30	100-160	60-130
1/8"	225-360	25-40	150-210	100-180
5/32"	360-450	40-55	200-275	160-240
3/16"	450-720	55-80	250-350	190-300
1/4"	720-950	80-125	325-450	250-400
Zirconium Alloyed Tungsten (Brown Band)				
.010"	*	*	Up to 20	Up to 15
.020"	*	*	15-35	5-20
.040"	*	*	20-80	20-60
1/16"	*	*	50-150	60-120
3/32"	*	*	130-250	100-180
1/8"	*	*	225-360	160-250
5/32"	*	*	300-450	200-320
3/16"	*	*	400-550	290-390
1/4"	*	*	600-800	340-525

♦ Typical argon shielding gas flow rates are 15 to 35 cfh (cubic feet per hour).

*Not Recommended.

Figures listed are a guide and are a composite of recommendations from American Welding Society (AWS) and electrode manufacturers.

7-2. Preparing Tungsten Electrode For Welding



▲ Grinding the tungsten electrode produces dust and flying sparks which can cause injury and start fires. Use local exhaust (forced ventilation) at the grinder or wear an approved respirator. Read MSDS for safety information. Consider using tungsten containing ceria, lanthana, or yttria instead of thorium. Grinding dust from thoriated electrodes contains low-level radioactive material. Properly dispose of grinder dust in an environmentally safe way. Wear proper face, hand, and body protection. Keep flammables away.

A. Preparing Tungsten For DC Electrode Negative (DCEN) Welding Or AC Welding With Inverter Machines

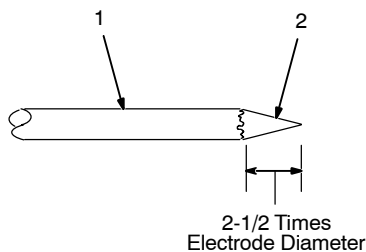

- 1 Tungsten Electrode
- 2 Tapered End

Grind end of tungsten on fine grit, hard abrasive wheel before welding. Do not use wheel for other jobs or tungsten can become contaminated causing lower weld quality.

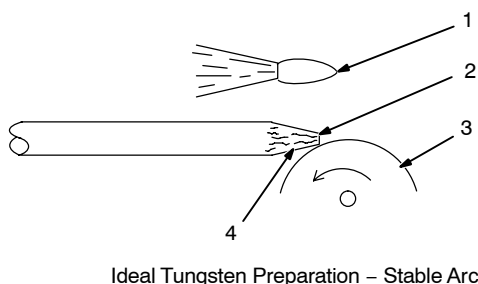

- 1 Stable Arc
 - 2 Flat
 - 3 Grinding Wheel
 - 4 Straight Ground
- Diameter of this flat determines amperage capacity.
Grinding wheel should be dedicated to grinding tungsten only.

Ideal Tungsten Preparation – Stable Arc

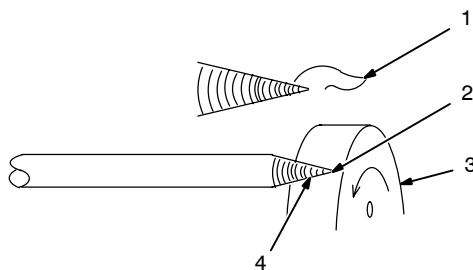

- 1 Arc Wander
 - 2 Point
 - 3 Grinding Wheel
 - 4 Radial Ground
- Grinding wheel should be dedicated to grinding tungsten only.

Wrong Tungsten Preparation – Wandering Arc

B. Preparing Tungsten For Conventional AC Welding

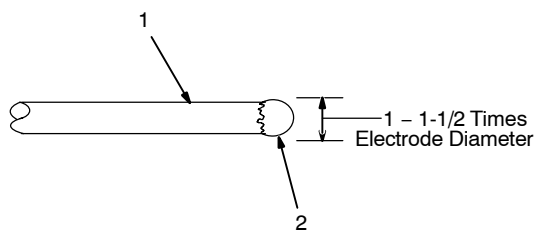

- 1 Tungsten Electrode
 - 2 Balled End
- ▲ Understand and follow safety symbols at start of Section 8-1 before preparing tungsten.

Ball end of tungsten by applying AC amperage recommended for a given electrode diameter (see Section 7-1). Let ball on end of the tungsten take its own shape.

SECTION 8 – GUIDELINES FOR TIG WELDING (GTAW)

8-1. Positioning The Torch

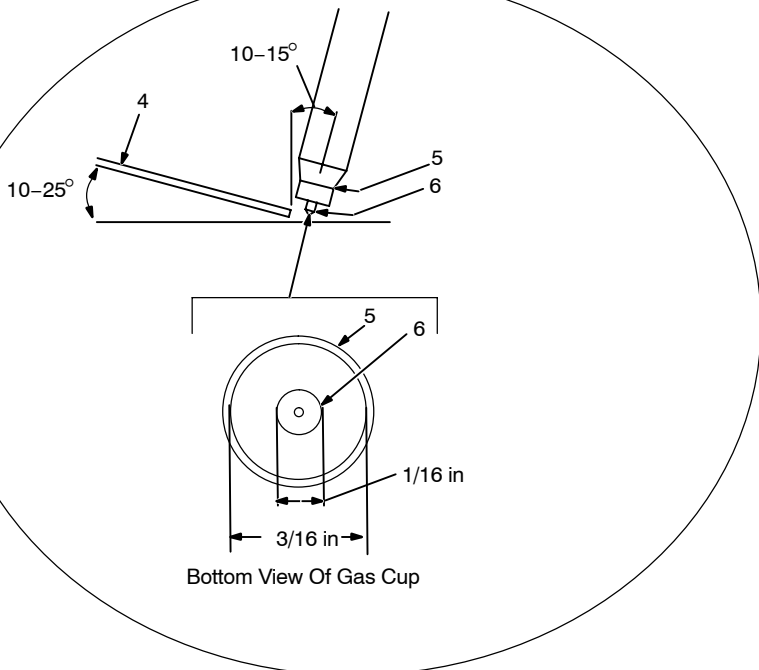
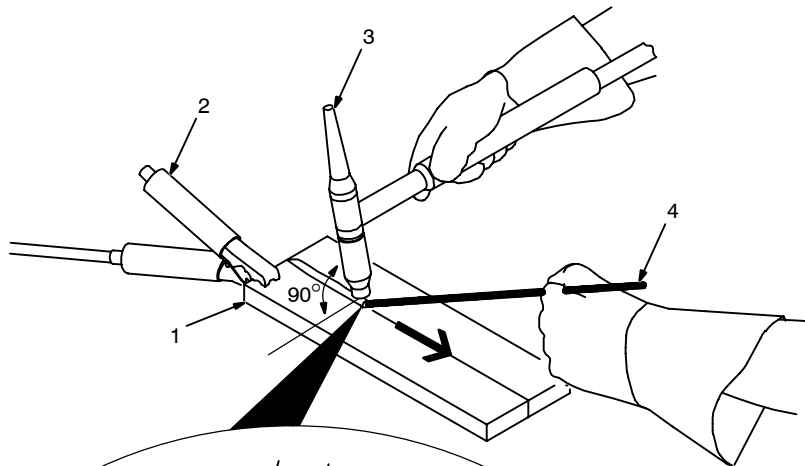

▲ Weld current can damage electronic parts in vehicles. Disconnect both battery cables before welding on a vehicle. Place work clamp as close to the weld as possible.

☞ For additional information, see your distributor for a handbook on the Gas Tungsten Arc Welding (GTAW) process.

1 Workpiece

Make sure workpiece is clean before welding.

2 Work Clamp

Place as close to the weld as possible.

3 Torch

4 Filler Rod (If Applicable)

5 Gas Cup

6 Tungsten Electrode

Select and prepare tungsten according to Sections 7-1 and 7-2.

Guidelines:

The inside diameter of the gas cup should be at least three times the tungsten diameter to provide adequate shielding gas coverage. (For example, if tungsten is 1/16 in diameter, gas cup should be a minimum of 3/16 in diameter.)

Tungsten extension is the distance the tungsten extends out gas cup of torch.

The tungsten extension should be no greater than the inside diameter of the gas cup.

Arc length is the distance from the tungsten to the workpiece.

8-2. Torch Movement During Welding

Tungsten Without Filler Rod

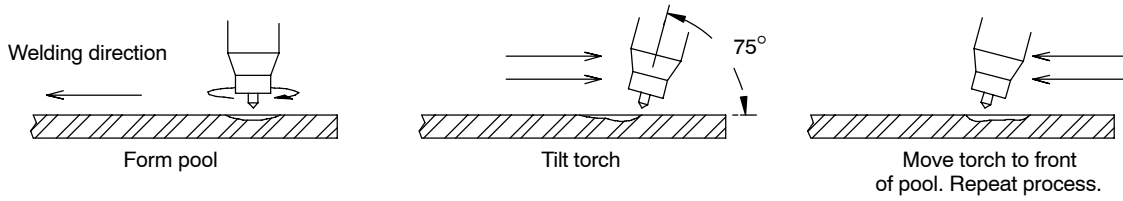

Tungsten With Filler Rod

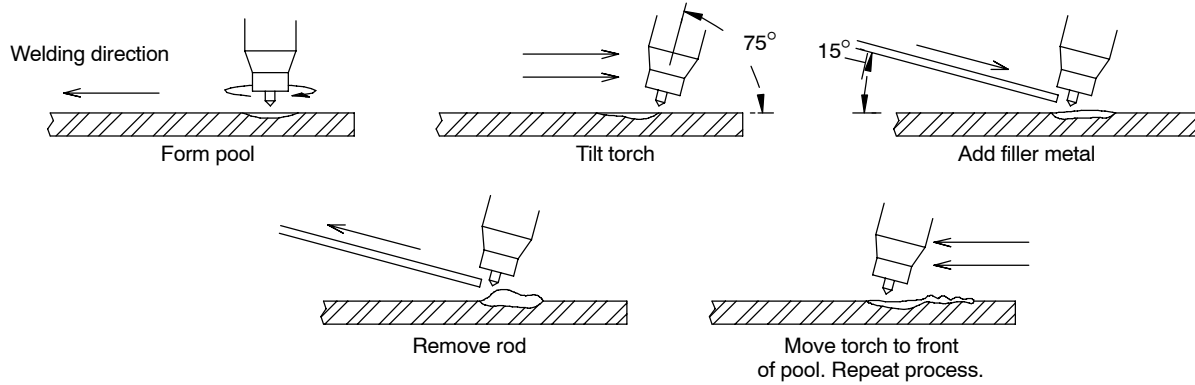

ST-162 002-B

8-3. Positioning Torch Tungsten For Various Weld Joints

Butt Weld And Stringer Bead

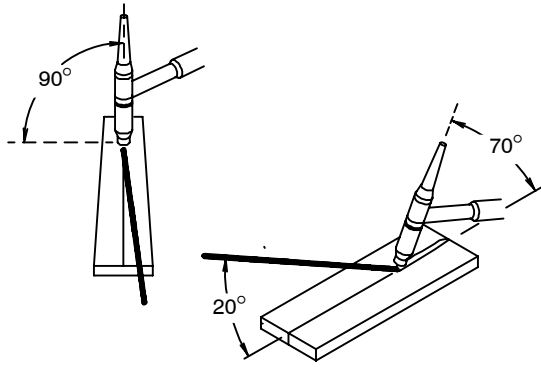

"T" Joint

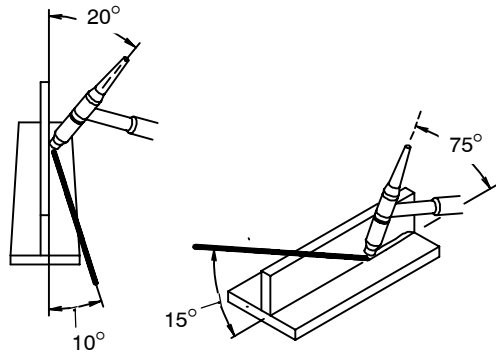
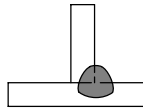

Lap Joint

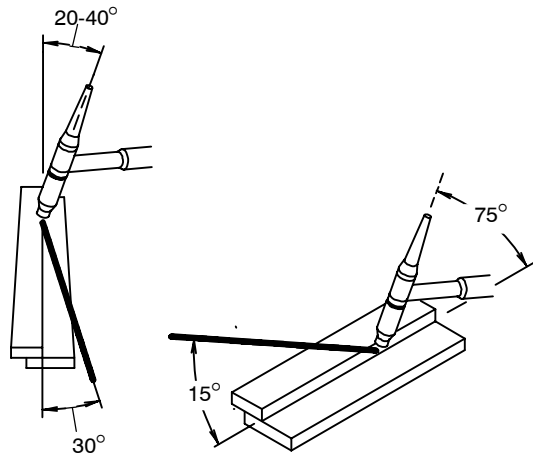
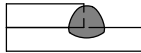

Corner Joint

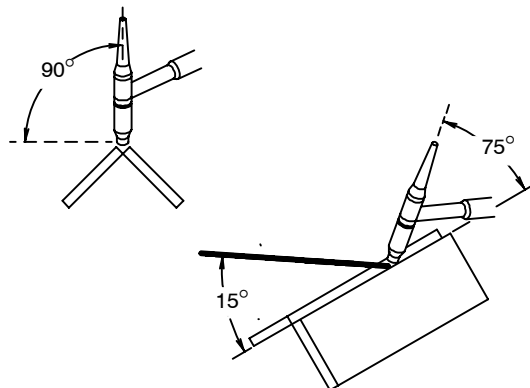
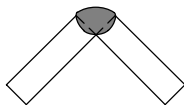

SECTION 9 – STICK WELDING (SMAW) GUIDELINES



9-1. Stick Welding Procedure

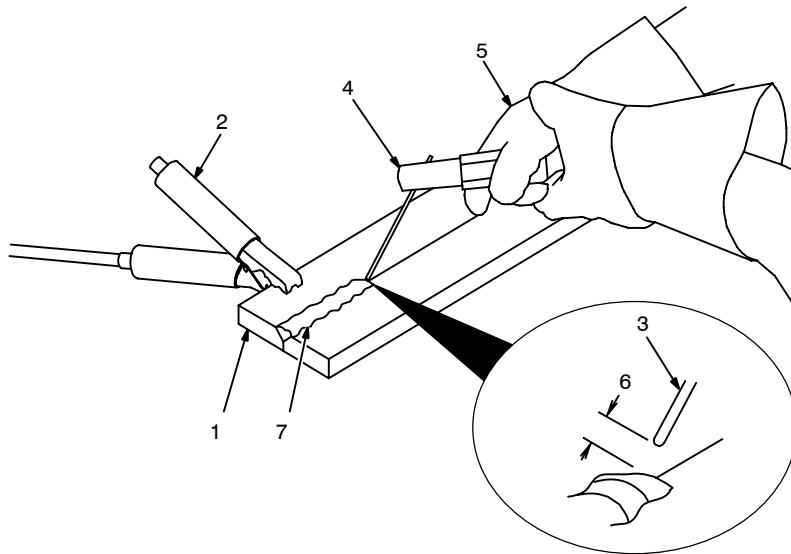

▲ Weld current starts when electrode touches workpiece.

▲ Weld current can damage electronic parts in vehicles. Disconnect both battery cables before welding on a vehicle. Place work clamp as close to the weld as possible.

1 Workpiece

Make sure workpiece is clean before welding.

2 Work Clamp

3 Electrode

A small diameter electrode requires less current than a large one. Follow electrode manufacturer's instructions when setting weld amperage (see Section 9-2).

4 Insulated Electrode Holder

5 Electrode Holder Position

6 Arc Length

Arc length is the distance from the electrode to the workpiece. A short arc with correct amperage will give a sharp, crackling sound.

7 Slag

Use a chipping hammer and wire brush to remove slag. Remove slag and check weld bead before making another weld pass.

Tools Needed:

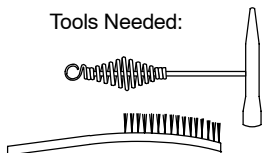

9-2. Electrode and Amperage Selection Chart

ELECTRODE	DIAMETER	AMPERAGE RANGE								
		50	100	150	200	250	300	350	400	450
6010 & 6011	3/32									
	1/8									
	5/32									
	3/16									
	7/32									
6013	1/4									
	1/16									
	5/64									
	3/32									
	1/8									
	5/32									
	3/16									
7014	7/32									
	1/4									
	3/32									
	1/8									
	5/32									
7018	3/16									
	7/32									
	1/4									
	3/32									
	1/8									
7024	5/32									
	3/16									
	7/32									
	1/4									
	3/32									
Ni-CI	1/8									
	5/32									
	3/16									
308L	3/32									
	1/8									
	5/32									

ELECTRODE	DC*	AC	POSITION	PENETRATION	USAGE
6010	EP		ALL	DEEP	MIN. PREP, ROUGH
6011	EP	✓	ALL	DEEP	HIGH SPATTER
6013	EP,EN	✓	ALL	LOW	GENERAL
7014	EP,EN	✓	ALL	MED	SMOOTH, EASY, FAST
7018	EP	✓	ALL	LOW	LOW HYDROGEN, STRONG
7024	EP,EN	✓	FLAT HORIZ FILLET	LOW	SMOOTH, EASY, FASTER
NI-CL	EP	✓	ALL	LOW	CAST IRON
308L	EP	✓	ALL	LOW	STAINLESS

*EP = ELECTRODE POSITIVE (REVERSE POLARITY)
EN = ELECTRODE NEGATIVE (STRAIGHT POLARITY)

Ref. S-087 985-A

9-3. Striking an Arc – Scratch Start Technique

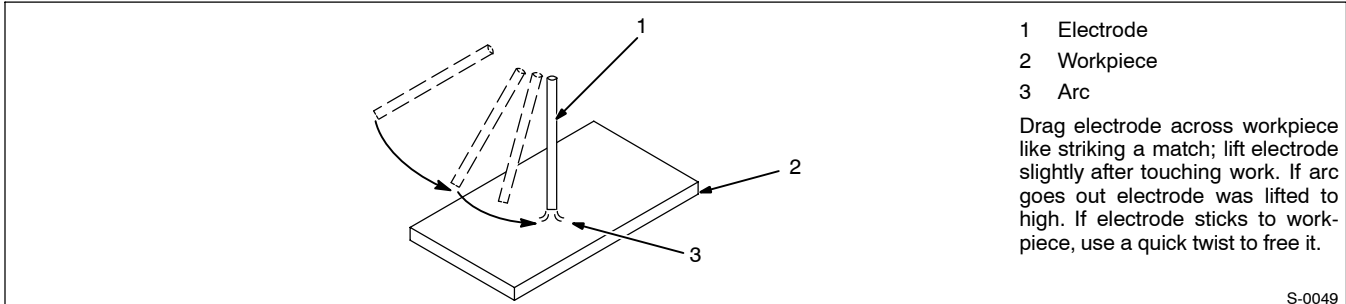

S-0049

9-4. Striking an Arc – Tapping Technique

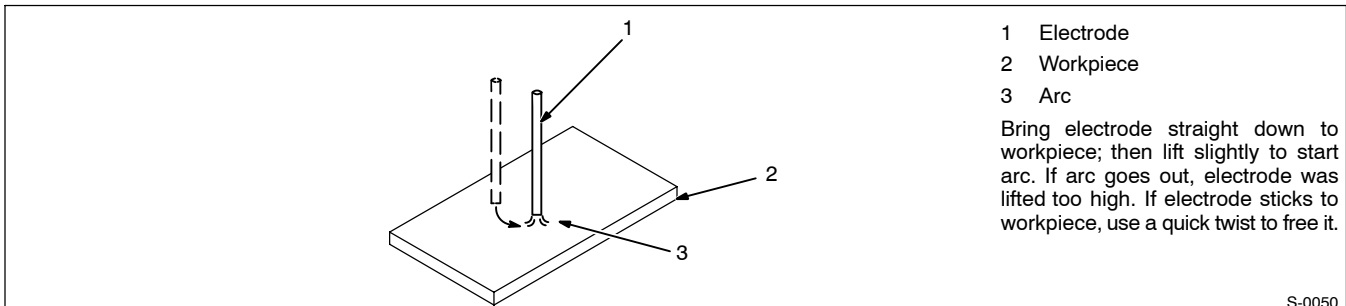

S-0050

9-5. Positioning Electrode Holder

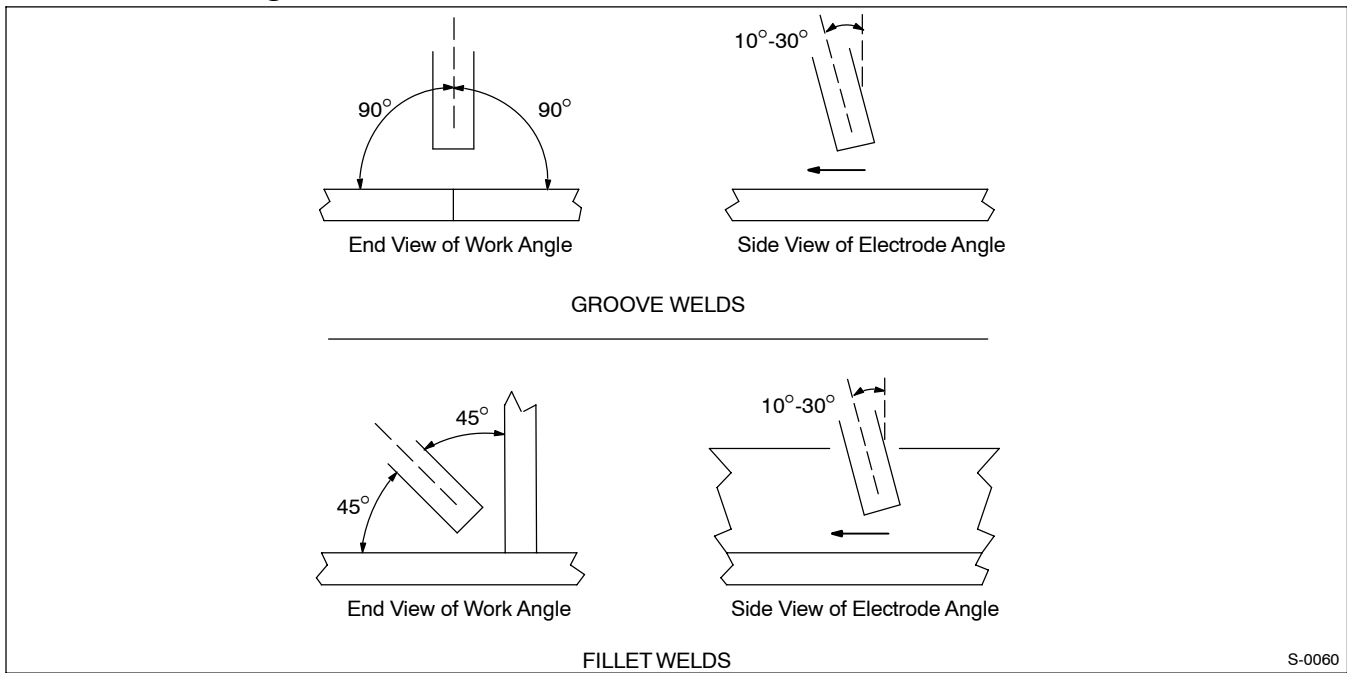

9-6. Poor Weld Bead Characteristics

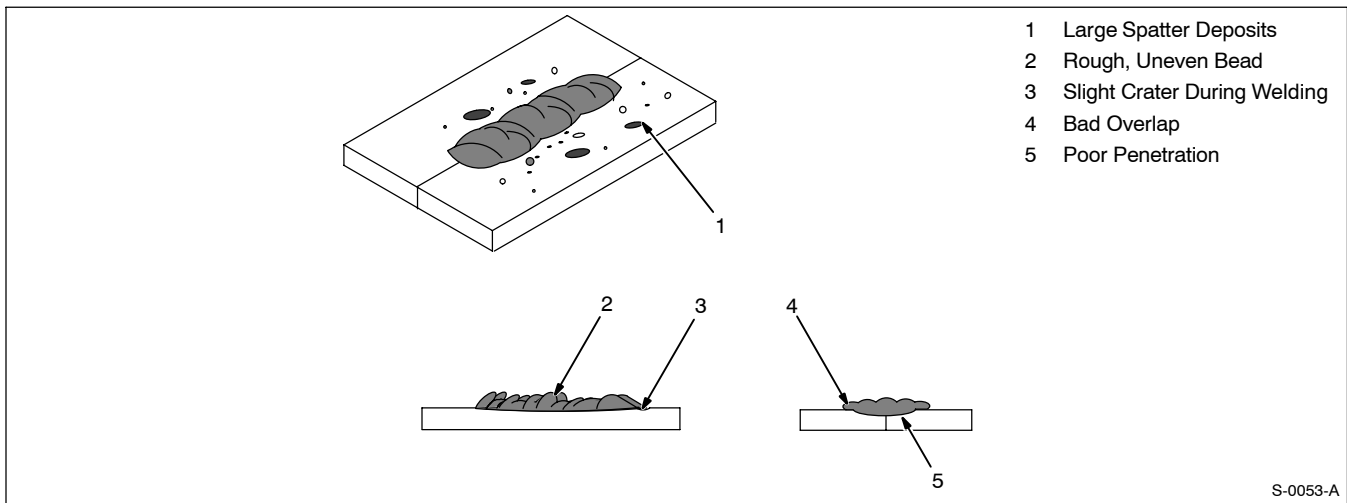

9-7. Good Weld Bead Characteristics

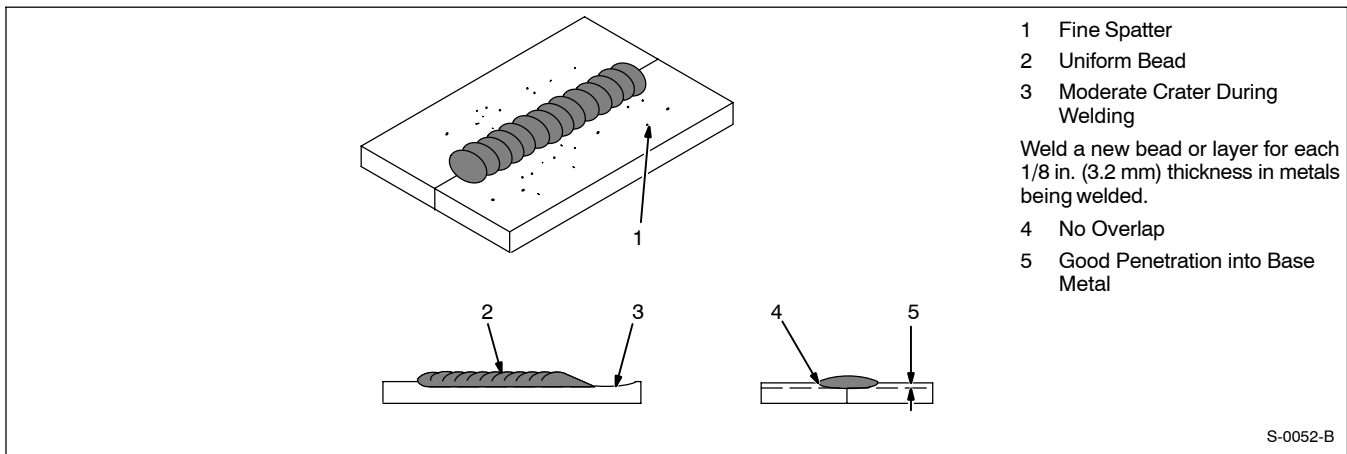

9-8. Conditions That Affect Weld Bead Shape

NOTE

Weld bead shape is affected by electrode angle, arc length, travel speed, and thickness of base metal.

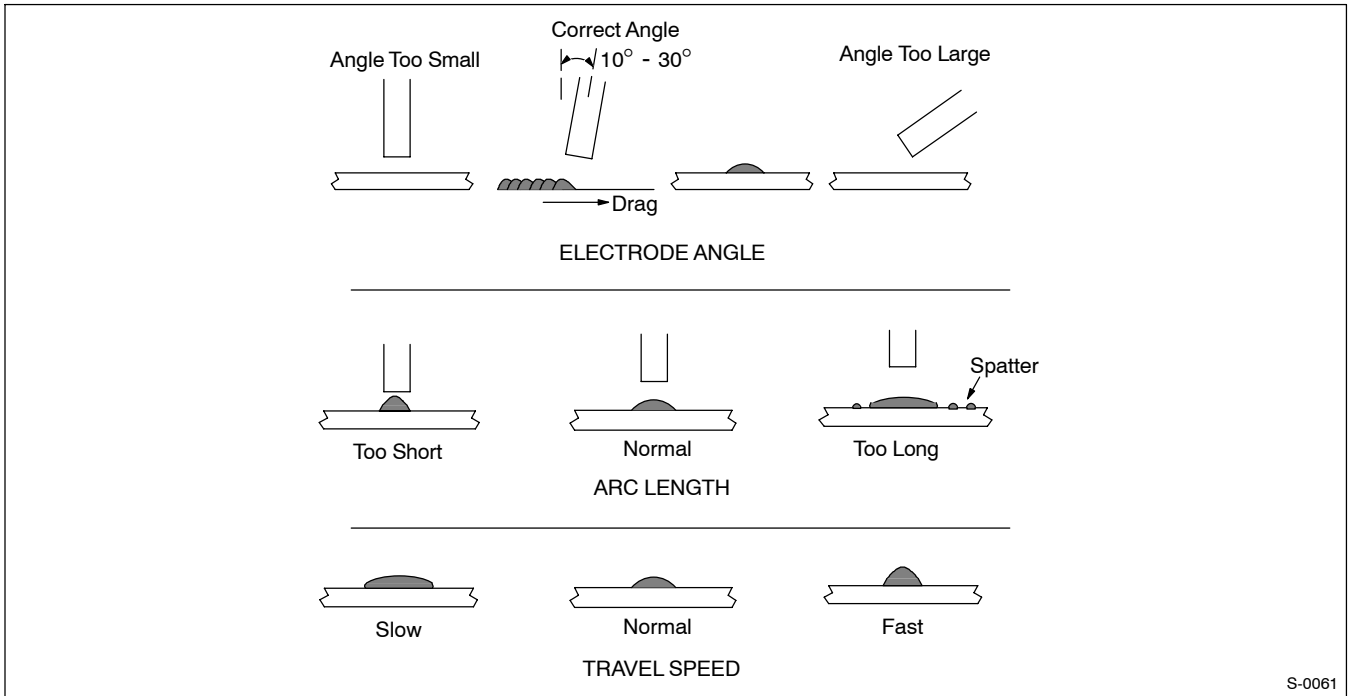

9-9. Electrode Movement During Welding

NOTE

Normally, a single stringer bead is satisfactory for most narrow groove weld joints; however, for wide groove weld joints or bridging across gaps, a weave bead or multiple stringer beads work better.

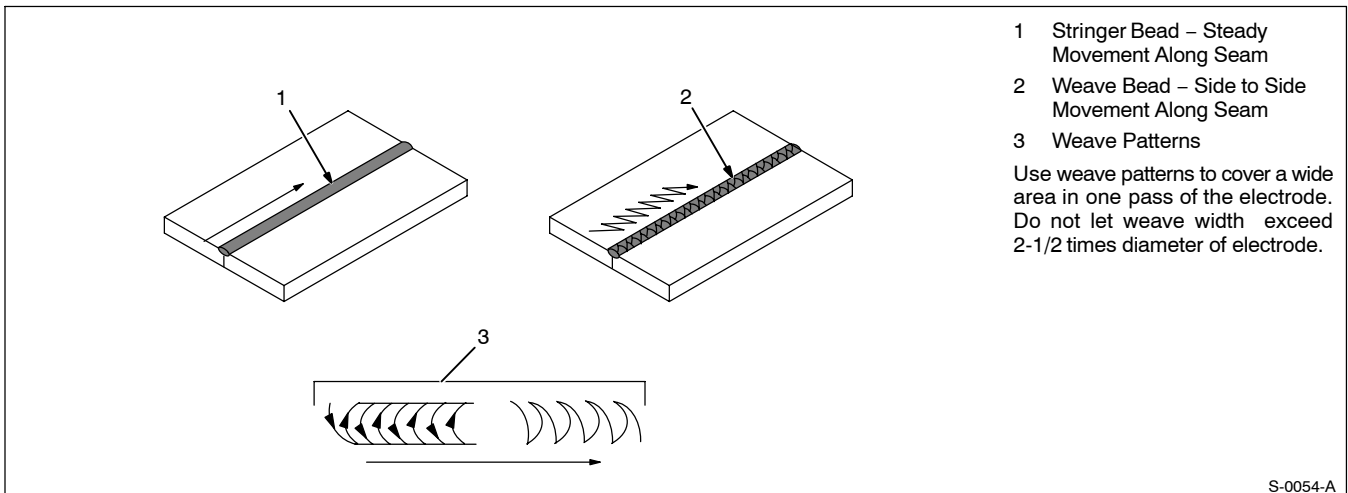

9-10. Butt Joints

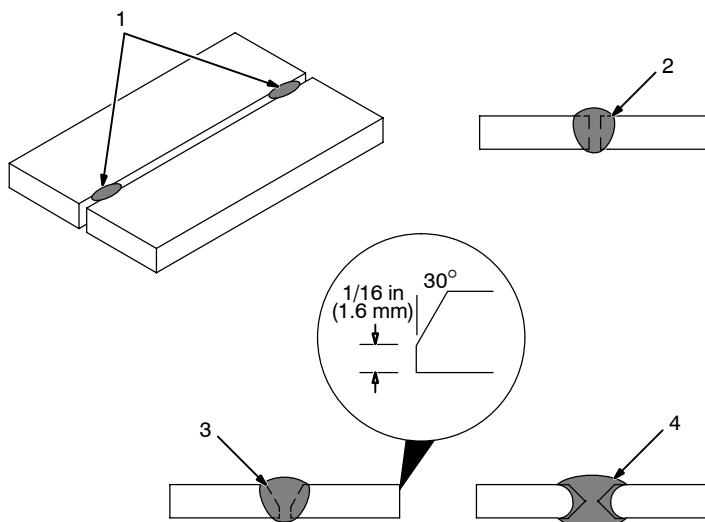

1 Tack Welds

Prevent edges of joint from drawing together ahead of electrode by tack welding the materials in position before final weld.

2 Square Groove Weld

Good for materials up to 3/16 in (5 mm) thick.

3 Single V-Groove Weld

Good for materials 3/16 – 3/4 in (5-19 mm) thick. Cut bevel with oxy-acetylene or plasma cutting equipment. Remove scale from material after cutting. A grinder can also be used to prepare bevels.

Create 30 degree angle of bevel on materials in V-groove welding.

4 Double V-Groove Weld

Good for materials thicker than 3/16 in (5 mm).

S-0662

9-11. Lap Joint

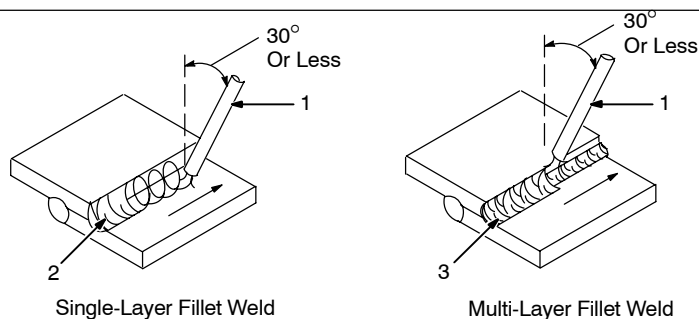

1 Electrode

2 Single-Layer Fillet Weld

Move electrode in circular motion.

3 Multi-Layer Fillet Weld

Weld a second layer when a heavier fillet is needed. Remove slag before making another weld pass. Weld both sides of joint for maximum strength.

S-0063 / S-0064

9-12. Tee Joint

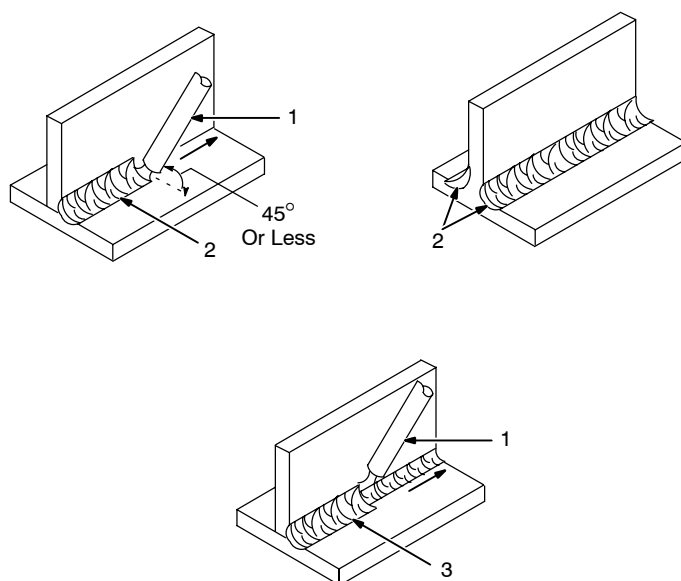

1 Electrode

2 Fillet Weld

Keep arc short and move at definite rate of speed. Hold electrode as shown to provide fusion into the corner. Square edge of the weld surface.

For maximum strength weld both sides of upright section.

3 Multi-Layer Deposits

Weld a second layer when a heavier fillet is needed. Use any of the weaving patterns shown in Section 9-9. Remove slag before making another weld pass.

S-0060 / S-0058-A / S-0061

9-13. Weld Test

1 Vise
2 Weld Joint
3 Hammer

Strike weld joint in direction shown. A good weld bends over but does not break.

S-0057-B

9-14. Troubleshooting – Porosity

Porosity – small cavities or holes resulting from gas pockets in weld metal.

Possible Causes	Corrective Actions
Arc length too long.	Reduce arc length.
Damp electrode.	Use dry electrode.
Workpiece dirty.	Remove all grease, oil, moisture, rust, paint, coatings, slag, and dirt from work surface before welding.

9-15. Troubleshooting – Excessive Spatter

Excessive Spatter – scattering of molten metal particles that cool to solid form near weld bead.

Possible Causes	Corrective Actions
Amperage too high for electrode.	Decrease amperage or select larger electrode.
Arc length too long or voltage too high.	Reduce arc length or voltage.

9-16. Troubleshooting – Incomplete Fusion

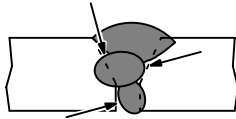
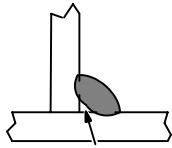

Incomplete Fusion – failure of weld metal to fuse completely with base metal or a preceding weld bead.

Possible Causes	Corrective Actions
Insufficient heat input.	Increase amperage. Select larger electrode and increase amperage.
Improper welding technique.	Place stringer bead in proper location(s) at joint during welding.
	Adjust work angle or widen groove to access bottom during welding.
	Momentarily hold arc on groove side walls when using weaving technique.
	Keep arc on leading edge of weld puddle.
Workpiece dirty.	Remove all grease, oil, moisture, rust, paint, coatings, slag, and dirt from work surface before welding.

9-17. Troubleshooting – Lack Of Penetration

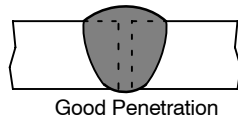
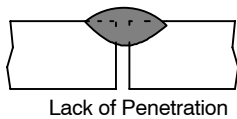

Lack Of Penetration – shallow fusion between weld metal and base metal.

Possible Causes	Corrective Actions
Improper joint preparation.	Material too thick. Joint preparation and design must provide access to bottom of groove.
Improper weld technique.	Keep arc on leading edge of weld puddle.
Insufficient heat input.	Increase amperage. Select larger electrode and increase amperage.
	Reduce travel speed.

9-18. Troubleshooting – Excessive Penetration

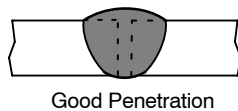
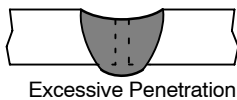

Excessive Penetration – weld metal melting through base metal and hanging underneath weld.

Possible Causes	Corrective Actions
Excessive heat input.	Select lower amperage. Use smaller electrode.
	Increase and/or maintain steady travel speed.

9-19. Troubleshooting – Burn-Through

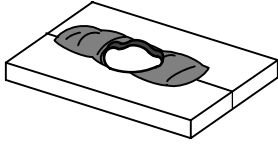

Burn-Through – weld metal melting completely through base metal resulting in holes where no metal remains.

Possible Causes	Corrective Actions
Excessive heat input.	Select lower amperage. Use smaller electrode.
	Increase and/or maintain steady travel speed.

9-20. Troubleshooting – Waviness Of Bead

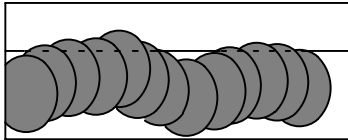

Waviness Of Bead – weld metal that is not parallel and does not cover joint formed by base metal.

Possible Causes	Corrective Actions
Unsteady hand.	Use two hands. Practice technique.

9-21. Troubleshooting – Distortion

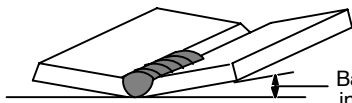

Base metal moves in the direction of the weld bead.

Distortion – contraction of weld metal during welding that forces base metal to move.

Possible Causes	Corrective Actions
Excessive heat input.	Use restraint (clamp) to hold base metal in position.
	Make tack welds along joint before starting welding operation.
	Select lower amperage for electrode.
	Increase travel speed.
	Weld in small segments and allow cooling between welds.

TRUE BLUE[®]

WARRANTY

Effective January 1, 2006

(Equipment with a serial number preface of "LG" or newer)

This limited warranty supersedes all previous Miller warranties and is exclusive with no other guarantees or warranties expressed or implied.

LIMITED WARRANTY – Subject to the terms and conditions below, Miller Electric Mfg. Co., Appleton, Wisconsin, warrants to its original retail purchaser that new Miller equipment sold after the effective date of this limited warranty is free of defects in material and workmanship at the time it is shipped by Miller. THIS WARRANTY IS EXPRESSLY IN LIEU OF ALL OTHER WARRANTIES, EXPRESS OR IMPLIED, INCLUDING THE WARRANTIES OF MERCHANTABILITY AND FITNESS.

Within the warranty periods listed below, Miller will repair or replace any warranted parts or components that fail due to such defects in material or workmanship. Miller must be notified in writing within thirty (30) days of such defect or failure, at which time Miller will provide instructions on the warranty claim procedures to be followed.

Miller shall honor warranty claims on warranted equipment listed below in the event of such a failure within the warranty time periods. All warranty time periods start on the date that the equipment was delivered to the original retail purchaser, or one year after the equipment is sent to a North American distributor or eighteen months after the equipment is sent to an International distributor.

- 5 Years Parts — 3 Years Labor
 - * Original main power rectifiers
- 3 Years — Parts and Labor
 - * Transformer/Rectifier Power Sources
 - * Plasma Arc Cutting Power Sources
 - * Process Controllers
 - * Semi-Automatic and Automatic Wire Feeders
 - * Inverter Power Sources (Unless Otherwise Stated)
 - * Water Coolant Systems (Integrated)
 - * Intellitig
 - * Engine Driven Welding Generators
(NOTE: Engines are warranted separately by the engine manufacturer.)
- 1 Year — Parts and Labor Unless Specified
 - * Motor Driven Guns (w/exception of Spoolmate Spoolguns)
 - * Positioners and Controllers
 - * Automatic Motion Devices
 - * RFCS Foot Controls
 - * Induction Heating Power Sources, Coolers, and Electronic Controls/Recorders
 - * Water Coolant Systems (Non-Integrated)
 - * Flowgauge and Flowmeter Regulators (No Labor)
 - * HF Units
 - * Grids
 - * Spot Welders
 - * Load Banks
 - * Arc Stud Power Sources & Arc Stud Guns
 - * Racks
 - * Running Gear/Trailers
 - * Plasma Cutting Torches (except APT & SAF Models)
 - * Field Options
(NOTE: Field options are covered under True Blue[®] for the remaining warranty period of the product they are installed in, or for a minimum of one year — whichever is greater.)
 - * Bernard-Branded Mig Guns (No Labor)
 - * Weldcraft-Branded TIG Torches (No Labor)
 - * Subarc Wire Drive Assemblies
- 6 Months — Batteries
- 90 Days — Parts
 - * MIG Guns/TIG Torches and Subarc (SAW) Guns

- * Induction Heating Coils and Blankets, Cables, and Non-Electronic Controls
- * APT & SAF Model Plasma Cutting Torches
- * Remote Controls
- * Accessory (Kits)
- * Replacement Parts (No labor)
- * Spoolmate Spoolguns
- * Canvas Covers

Miller's True Blue[®] Limited Warranty shall not apply to:

- Consumable components; such as contact tips, cutting nozzles, contactors, brushes, slip rings, relays or parts that fail due to normal wear. (Exception: brushes, slip rings, and relays are covered on Bobcat, Trailblazer, and Legend models.)**
- Items furnished by Miller, but manufactured by others, such as engines or trade accessories. These items are covered by the manufacturer's warranty, if any.
- Equipment that has been modified by any party other than Miller, or equipment that has been improperly installed, improperly operated or misused based upon industry standards, or equipment which has not had reasonable and necessary maintenance, or equipment which has been used for operation outside of the specifications for the equipment.

MILLER PRODUCTS ARE INTENDED FOR PURCHASE AND USE BY COMMERCIAL/INDUSTRIAL USERS AND PERSONS TRAINED AND EXPERIENCED IN THE USE AND MAINTENANCE OF WELDING EQUIPMENT.

In the event of a warranty claim covered by this warranty, the exclusive remedies shall be, at Miller's option: (1) repair; or (2) replacement; or, where authorized in writing by Miller in appropriate cases, (3) the reasonable cost of repair or replacement at an authorized Miller service station; or (4) payment of or credit for the purchase price (less reasonable depreciation based upon actual use) upon return of the goods at customer's risk and expense. Miller's option of repair or replacement will be F.O.B., Factory at Appleton, Wisconsin, or F.O.B. at a Miller authorized service facility as determined by Miller. Therefore no compensation or reimbursement for transportation costs of any kind will be allowed.

TO THE EXTENT PERMITTED BY LAW, THE REMEDIES PROVIDED HEREIN ARE THE SOLE AND EXCLUSIVE REMEDIES. IN NO EVENT SHALL MILLER BE LIABLE FOR DIRECT, INDIRECT, SPECIAL, INCIDENTAL OR CONSEQUENTIAL DAMAGES (INCLUDING LOSS OF PROFIT), WHETHER BASED ON CONTRACT, TORT OR ANY OTHER LEGAL THEORY.

ANY EXPRESS WARRANTY NOT PROVIDED HEREIN AND ANY IMPLIED WARRANTY, GUARANTY OR REPRESENTATION AS TO PERFORMANCE, AND ANY REMEDY FOR BREACH OF CONTRACT TORT OR ANY OTHER LEGAL THEORY WHICH, BUT FOR THIS PROVISION, MIGHT ARISE BY IMPLICATION, OPERATION OF LAW, CUSTOM OF TRADE OR COURSE OF DEALING, INCLUDING ANY IMPLIED WARRANTY OF MERCHANTABILITY OR FITNESS FOR PARTICULAR PURPOSE, WITH RESPECT TO ANY AND ALL EQUIPMENT FURNISHED BY MILLER IS EXCLUDED AND DISCLAIMED BY MILLER.

Some states in the U.S.A. do not allow limitations of how long an implied warranty lasts, or the exclusion of incidental, indirect, special or consequential damages, so the above limitation or exclusion may not apply to you. This warranty provides specific legal rights, and other rights may be available, but may vary from state to state.

In Canada, legislation in some provinces provides for certain additional warranties or remedies other than as stated herein, and to the extent that they may not be waived, the limitations and exclusions set out above may not apply. This Limited Warranty provides specific legal rights, and other rights may be available, but may vary from province to province.

miller_warr 2006-01

Warranty Questions?

Call
1-800-4-A-MILLER
for your local
Miller distributor.

Your distributor also gives you ...

Service

You always get the fast, reliable response you need. Most replacement parts can be in your hands in 24 hours.

Support

Need fast answers to the tough welding questions? Contact your distributor. The expertise of the distributor and Miller is there to help you, every step of the way.





Owner's Record

Please complete and retain with your personal records.

Model Name

Serial/Style Number

Purchase Date

(Date which equipment was delivered to original customer.)

Distributor

Address

City

State

Zip



For Service

Contact a DISTRIBUTOR or SERVICE AGENCY near you.

Always provide Model Name and Serial/Style Number.

Contact your Distributor for:

Welding Supplies and Consumables

Options and Accessories

Personal Safety Equipment

Service and Repair

Replacement Parts

Training (Schools, Videos, Books)

Technical Manuals (Servicing Information and Parts)

Circuit Diagrams

Welding Process Handbooks

To locate a Distributor or Service Agency visit www.millerwelds.com or call 1-800-4-A-Miller

Contact the Delivering Carrier to:

File a claim for loss or damage during shipment.

For assistance in filing or settling claims, contact your distributor and/or equipment manufacturer's Transportation Department.

Miller Electric Mfg. Co.

An Illinois Tool Works Company
1635 West Spencer Street
Appleton, WI 54914 USA

International Headquarters—USA

USA Phone: 920-735-4505 Auto-Attended
USA & Canada FAX: 920-735-4134
International FAX: 920-735-4125

European Headquarters – United Kingdom

Phone: 44 (0) 1204-593493
FAX: 44 (0) 1204-598066

www.MillerWelds.com

